

REVIEW ON SEMANTIC SEGMENTATION UTILIZING DEEP LEARNING TECHNIQUES

Sanjay Kumar Padhi¹

Aryan Institute of Engineering & Technology, Bhubaneswar

Santosh Kumar Sharma²

NM Institute of Engineering and Technology, Bhubaneswar, Odisha

Ashis Acharya³

Capital Engineering College, Bhubaneswar, Odisha

Aradhana Panda⁴

Raajdhani Engineering College, Bhubaneswar, Odisha

Abstract

In computer vision systems Semantic segmentation is a challenging task. Many methods have been created to tackle this problem ranging from autonomous vehicles, interaction between human and computer, to robotics, research on medical science, agriculture and so on. Many of these methods have been built using the deep learning network that has shown a salient performance. For this reason, we propose to survey these methods by, first categorizing them into ten different classes according to the common concepts underlying their architectures. Second, by providing an overview of the publicly available datasets on which they have been assessed. In addition, we present the common evaluation matrix used to measure their accuracy. Moreover, we focus on some of the methods and look closely at their architectures in order to find out how they have achieved their reported performances. Finally, we conclude by discussing some of the open problems and their possible solutions.

Keywords: Deep Learning, Semantic Segmentation, Recurrent Neural Network, Semi-weakly supervised networks

1. Introduction

The recent works in deep learning dealing with semantic segmentation have been significantly improved by using neural networks. Neural networks have a long history since the 1940s and they did not get much of the attention of researchers until 1990s [1]. Neural networks made huge progress because of large amount of data is available thanks to the rise of digital cameras, cell phone cameras, and the computing power, which is getting faster as GPUs become general purpose computing tools.

Deep neural networks are very effective in semantic segmentation, that is labeling each region or pixel with a class of objects/non-objects. Semantic segmentation plays an important role in image understanding and essential for image analysis tasks. It has several applications in computer vision & artificial intelligence - autonomous driving [2, 3], robot navigation [4], industrial inspection [5]; remote sensing [6]; In cognitive and computational sciences - saliency object detection [7, 8]; In Agriculture sciences [9]; Fashion - categorizing clothing items [10]; In medical sciences - medical imaging analysis [11] etc. The earlier approaches used for semantic segmentation were textonforest [12], random-forest based classifiers [13], whereas deep learning techniques allowed precise and much faster seg-

mentation [14].

Semantic segmentation requires image classification, object detection, and boundary localization. Figure 1 is an example of object detection, involving bounding box, and classification of each pixel into different classes (car, road, sky, vegetation, terrain etc).

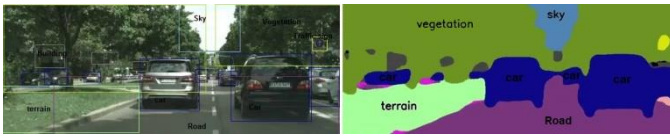

Figure 1: Object Detection / Bounding Box and Semantic Segmentation

Deep learning is a new field division of machine learning, which is rapidly growing with the pace making it very difficult to stay up to date, even to keep track of the works dealing with semantic segmentation. These works cover the development of new methods, improvements of existing methods, and their deployment in new application domains. This is the reason that there is a lack of state-of-the-art reviews. Some surveys and review papers have addressed advancements and innovations on the subject of deep learning and semantic segmentation. A Survey by Zhu et

al. [15] covering a wide range of the papers and areas of semantic segmentation top-ics including, interactive methods, recent development in the super-pixel, object proposals, semantic image parsing, image co-segmentation, semi & weakly supervised, and fully supervised image segmentation. Martin Thoma [16] presented a taxonomy of segmentation algorithms and overview of completely automatic, passive, semantic segmentation algorithms. Niemeijer et al. [17] presented a review of neural network based semantic segmentation for scene understanding in the context of the autonomous driving. Guo et al. [18] provided a review of semantic segmentation approaches, i.e., region-based, FCN-based and weakly supervised approaches. They have summarized the strengths, weaknesses and major challenges in image semantic segmentation. Geng et al. [19] presented a survey of recent progress in semantic segmentation with CNN's, and newly developed strategies that have achieved promising results on the Pascal VOC 2012 semantic segmentation challenge.

Detail review provided by Garcia et al. [20] on deep learning methods for semantic segmentation with their contributions and significance in the field. An extensive review presented by Hongshan et al. [21], categorized different methods based on hand engineered features, learned features, and weakly supervised learning.

The main contributions of this paper are as follows:

1. The existing methods have been categorized into ten different classes according to the common concept that underlies their architectures. This categorization gives a complete summary of the methods both inspire and diverge from one another.
2. More than 100 different models and 33 datasets (publicly available) have been covered, stating the corpus, original architecture, testing benchmark of each model, and the attributes of each dataset. Furthermore, we provide the best performing method yielded top classification accuracy on each dataset until date.
3. An emphasis on how these methods achieved their accomplishments is given by analyzing their structural design and their performance on the assessed datasets.
4. Finally, some of the open problems and possible solutions have been discussed.

In this survey, all the models are carefully chosen and put into relation to each other according to their architectural design and contribution to the field. This includes improving accuracy, reducing computation complexity, developing new methods, and enhancing existing ones. All the results reported in this paper are taken from the original papers. We have tried to cover most of the works in deep neural networks for semantic segmentation. This survey will help the new researchers to strengthen their understanding of these remarkable works.

2. Deep Learning Architectures for Semantic Segmentation

This section provides the details of all the reviewed semantic segmentation methods. We have categorized these methods into ten (10) classes, presented in the tabular form stating each method, its main idea, its architecture origin, testing benchmarks, publication date, and code availability (Table .13 provides links of available source codes).

The recent success of deep convolutional neural networks (CNNs) has enabled outstanding progress in semantic segmentation. The first successful application of convolutional neural network was developed by LeCun [22]. They introduced an architecture named LeNet5 to read zip codes, digits, and extract features at multiple locations in the image. Later, Alex Krizhevsky released a large deep convolutional neural network (AlexNet) [23], which is regarded as one of the most influential publications in the field. AlexNet is a deeper and wider version of the LeNet, used to learn complex objects and object hierarchies. Zeiler and Fergus [24] presented the ZFNet, which is a fine-tuning of the AlexNet structure. They proposed a technique of visualizing feature maps at any layer in the network

model. This technique uses a multi-layered deconvolutional

network to project the feature activations back to the input pixel space. Lin et al. [25] proposed a Network-In-Network model based on micro neural networks, which is a multilayer perceptron (MLP) [26], consisting of multiple fully connected layers with nonlinear activation functions. Szegedy et al. [27] proposed an efficient deep neural network called **GoogLeNet**. They introduced an inception module as shown in **Figure 2**, which is a combination of 1x1, 3x3, and 5x5 convolutional filters and a pooling layer. It reduced the number of features and operations at each layer thus saving the time and computational cost.

Figure 2: Inception module

The same authors proposed in [28] an algorithm referred as **BN-Inception** for constructing, training, and performing inference with Batch Normalization method. Szegedy et al. [29] further introduced two new modules **Inception V2** and **Inception V3** with some major modifications (i.e., factorizing convolutions and using grid reduction technique) of their previous module. Later, Szegedy et al. [30] replaced the filter concatenation stage of the Inception architecture with residual connections in order to increase efficiency and performance. They proposed Inception-ResNet-v1, Inception-ResNet-v2 and a pure Inception variant called Inception V4. Chollet et al. [31] proposed a module named **Xception**, meaning extreme inception. They replaced the inception modules with depth wise separable convolutions proposed in [32]. **Table 1** shows GoogLeNet Modules.

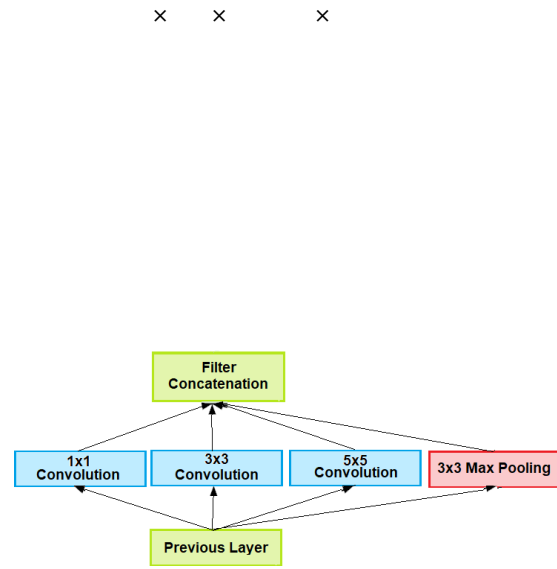

Feature Encoder Based Methods:

VGG [33] and ResNet [34] methods are the most dominant approaches for feature extraction. In this category, we review these methods and their invariants presented in **Table 2**. The idea behind the concept is to extract feature maps based on stacked convolution layers, ReLU layers and pooling layers.

VGG Network:

VGG network [33] introduced by Oxford's renowned Visual Geometry Group. Unlike LeNet [22] and AlexNet [23], VGGNet uses multiple 3x3 convolution in the sequence that can match the effect of larger receptive fields, e.g. 5x5 and 7x7. However, it required a large number of parameters and learning power due to having large classifiers. **Figure 3** shows a VGGNet with 16 convolutional layers.

Residual Learning Frameworks

Residual learning frameworks include methods which use residual block [34] as a fundamental building block in their architecture.

Table 1: GoogLeNet Modules

Model	Corpus	Original Architecture	Testing Benchmark	Published on	Code Available
GoogLeNet	Inception module: Bottleneck [27]	ININ	imagenet	September 17, 2014	YES
	Batch Normalization Modified BN-Inception [28]	Inception	ImageNet	March 2, 2015	YES
	Inception V2, V3 [29]	BN-Inception	ImageNet	December 11, 2015	YES
	Inception V4 and Inception-ResNet-v1, 2	Inception V3	ImageNet	August 23, 2016	YES
	Combining the Inception architecture with Residual connections [30]	ResNet			
Xception [31] Depthwise Separable Convolutions [32]	Inception V3 ResNet	ImageNet JFT (Google's) FastEval14k	April 4, 2017	YES	

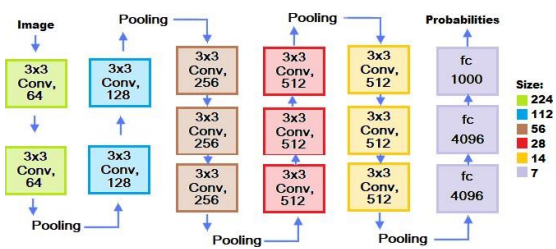

Figure 3: VGG-16 Layer Structure

Residual Network - ResNet [34] is the most popular and widely used neural network for semantic segmentation. It is hard to train a deep neural network with large numbers of layers, the more increase in depth, its performance gets saturated or even starts degrading due to vanishing gradient problem. Several solutions were proposed in [35, 36, 37] but none of them seemed to really tackle the problem. He et al. [34] resolved the vanishing gradient problem in an effective way by introducing identity shortcut connection (i.e., skipping one or more layers) as shown in **Figure 4**. They proposed a pre-activation variant residual block in which the gradients can easily flow through the shortcut connection without obstruction during the back pass of back propagation.

Several architectures are based on ResNet, its variants and interpretations. Paszke et al. [45] presented an encoder/decoder scheme network called efficient neural network (ENet). This network is similar to the ResNet bottleneck approach, created specifically for tasks requiring low latency operation, i.e., mobile phones or battery-powered devices. In [49, 50], the authors proposed counter-intuitive way of training a deep network by randomly dropping its layers and using the full network in testing time. Wu et al. [38] presented a neural network called ResNet-38, in which they added and removed layers in residual networks at train/test time. They analyzed the effective depths of residual units, and point out that ResNet behaves as linear ensembles of shallow networks. Pohlen et al. [44] proposed a full-resolution residual network (FRRN) with strong localization and recognition performance for semantic segmentation. FRRN exhibits the same superior training properties as ResNet, having two processing streams: residual and pooling. Residual

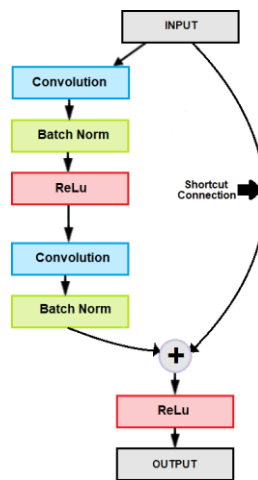

Figure 4: Residual Learning: A building block

stream carries information at the full image resolution and enables precise adherence to segment boundaries. The pooling stream undergoes a sequence of pooling operations to obtain robust features for recognition. The two streams are coupled at the full image resolution using residuals in order to realize strong recognition and localization performance for semantic segmentation. Xie et al. [41] proposed a modified ResNet called ResNeXt, following the split-transform-merge strategy as inception modules [27, 30], except the outputs of different paths are concatenated and all paths share the same topology. Thus, this allows the design to extend to any large number of transformations. Adapting the idea of ResNet-50 [34], an architecture called Adaptive network or AdapNet is proposed by Valada et al. [40]. They introduced an additional convolution with a kernel size of 3 3 before the first convolution layer in ResNet, which enables the network to learn more high resolution features in less time. They also proposed the convoluted mixture of deep experts (CMoDE) fusion scheme for learning robust kernels from complementary modalities and spectra. The proposed model adaptively weighs class-specific features based on the scene condition. Inspired by ENet, Romera et al. [46] proposed an efficient residual factorized network ERFNet for real-time semantic segmentation. ERFNet proposes a non-

Table 2: Feature Encoder based Methods

Category	Strategy / Structure	Corpus	Original Architecture	Testing Benchmark	Published on	Code Available			
Feature Encoder	Visual Geometry Group Network (VGGNet) [33]	Convolutional Networks (ConvNets) Used much smaller 3×3 filters in each convolutional layers which match the effect of larger receptive fields e.g. 5×5 and 7×7 .	AlexNet	ImageNet, PASCAL VOC	April 10, 2015	YES			
	R E S I D U A L	Residual Network (ResNet) [34]	Bottleneck Approach Shortcut Connections are added (MLPs-Multi Layer Perceptions)	VGG	Cityscapes, CIFAR-10, COCO, PASCAL VOC	December 10, 2015	YES		
		ResNet-38 [38]	(Shallow Network) ReNet for Image classification FCN for semantic image segmentation.	ResNet + FCN	Cityscapes, ADE20K, PASCAL VOC	November 30, 2016	YES		
		Fully Convolutional Dense ResNet (FC-DRN) [39]	Combining the strength of FC-ResNet: gradient flow and iterative refinement. FC-DenseNet: Multi-Scale feature representation and deep supervision).	ResNet	CamVid	April 30, 2018	-		
		Adaptive Network (AdapNet) [40]	Convolutud Mixture of Deep Experts (CMoDE) fusion scheme.	ResNet	Cityscapes, Synthia, Freiburg forest	May 29, 2017	-		
		ResNeXt [41]	Hyper-parameter "Cardinality" a new way to adjust models capacity.	ResNet	ImageNet, COCO, CIFAR	April 11, 2017	YES		
		INPLACE-ABN [42]	In-Place Activated Batch Normalization module: To reduce the training memory footprint of residual networks.	DeepLabV3	COCO-Stuff, Cityscapes Mapillary Vistas	December 11, 2017	YES		
		Dynamic-Structured Semantic Propagation Network (DSSPN) [43]	DSSPN explicitly constructs a semantic neuron graph network by incorporating the semantic concept hierarchy.	-	ADE20K, COCO-Stuff, Cityscape Mapillary	March 16, 2018	-		
	L E A R N I N G	Full-resolution Residual Networks (FRRN) [44]	Two Stream Network Residual Stream: Carries information at the full image resolution, enabling precise adherence to segment boundaries. Pooling Stream: Sequence of pooling operations to obtain robust features for recognition.	ResNet + VGG	Cityscapes	December 6, 2016	YES		
			Encoder Decoder	Efficient Neural Network (ENet) [45]	Presents a different view on encoder-decoder architecture The decoder is to upsample the output of the encoder, only to fine-tuning.	ResNet	Cityscapes, CamVid, SUN	June 7, 2016	YES
			Efficient Residual Factorized Network (ERFNet) [46]	A non-bottleneck-1D (non-bt-1D) layer and combines with bottleneck.	ResNet ENet	Cityscapes	January 1, 2018	YES	
			Efficient Spatial Pyramid ESPNet [47]	Efficient spatial pyramid (ESP) modules: Spatial pyramid of dilated convolutions.	ResNet	CityScapes, PASCAL VOC, Mapillary	March 22, 2018	YES	
			Restricted Deformable Convolution (RDC) Network [48]	Zoom Augmentation method: Transforming conventional images to fish-eye images.	ERFNet	CityScapes, SYNTHIA	January 3, 2018	-	
	F R A M E W O R K S	Encoder Decoder	Efficient Neural Network (ENet) [45]	Presents a different view on encoder-decoder architecture The decoder is to upsample the output of the encoder, only to fine-tuning.	ResNet	Cityscapes, CamVid, SUN	June 7, 2016	YES	
Efficient Residual Factorized Network (ERFNet) [46]			A non-bottleneck-1D (non-bt-1D) layer and combines with bottleneck.	ResNet ENet	Cityscapes	January 1, 2018	YES		
Efficient Spatial Pyramid ESPNet [47]			Efficient spatial pyramid (ESP) modules: Spatial pyramid of dilated convolutions.	ResNet	CityScapes, PASCAL VOC, Mapillary	March 22, 2018	YES		
Restricted Deformable Convolution (RDC) Network [48]			Zoom Augmentation method: Transforming conventional images to fish-eye images.	ERFNet	CityScapes, SYNTHIA	January 3, 2018	-		
Efficient Neural Network (ENet) [45]			Presents a different view on encoder-decoder architecture The decoder is to upsample the output of the encoder, only to fine-tuning.	ResNet	Cityscapes, CamVid, SUN	June 7, 2016	YES		

bottleneck-1D (non-bt-1D) layer and combines with bottleneck designs in a way that best leverages their learning performance and efficiency. Considering ERFNet as the baseline, Deng et al. [48] proposed a new encoder decoder approach called Restricted Deformable Convolution (RDC) for road scene semantic segmentation handling large distorted images. It can model geometric transformations by learning the shapes of convolutional filters conditioned on the input feature map. They proposed zoom augmentation method to convert standard images to fisheye images. Mehta et al. [47] proposed a convolutional module called efficient spatial pyramid (ESP) to their new efficient neural network. The ESP module consists of point-wise convolutions (reducing the complexity) and the spatial pyramid of dilated convolutions (providing large receptive field). Recently, Casanova et al. [39] proposed a Fully Convolutional Dense ResNet called FC-DRN. The basic idea is to combine the strength of the network architectures FC-ResNet (gradient flow and iterative refinement) and FC-DenseNet [51] (multi-scale feature representation and deep supervision). Liang et al. [43] proposed a Dynamic Structured Semantic Propagation Network (DSSPN), that builds a large semantic neuron graph by taking in the semantic concept hierarchy into network construction. In semantic propagation graph, each neuron is responsible for segmenting out regions of one concept in the word hierarchy. They proposed dense semantic-enhanced neural block in which the learned features of each neuron are further propagated into its child neurons to evolve features for recognizing more fine-grained concepts. Samuel et al. [42] present In-Place Activated Batch Normalization (INPLACE-ABN) architecture module to reduce the training memory footprint of residual network ResNeXt [41] and ResNet-38 [38].

The focus on VGG and ResNet approaches of recent works led to remarkable results in semantic segmentation. The residual learning frameworks follow the core idea "skip connection" which is the main intuition behind their success. However, using it in large scale can lead to memory problem. These groundbreaking works make it possible to train deeper networks with good performance.

Regional Proposal based Methods

Regional proposal algorithms are very influential in computer vision (for object detection techniques). The core idea is to detect the regions according to the variety of color spaces and similarity metrics, and then perform the classification (region proposals that might contain object) often called Region-wise prediction. Regional Convolutional Neural Network (R-CNN) along with its descendants shown in **Table 3**.

Girshick et al. [52] at UC Berkeley proposed a first region-based convolutional neural network (R-CNN) for object detection tasks. The R-CNN consists of three modules; regional proposal generator in which they used selective search method [53] performing the function of generating 2000 different regions that have the highest probability of containing an object; convolutional neural network [22] for extracting features from each region; finally these feature from CNN are used as input

to set of class specific linear SVMs. The features are also fed

into bounding box regressor to obtain the most accurate coordinates and reduce localization errors. Figure 5 shows R-CNN architecture.

Figure 5: The architecture of R-CNN [52]

In [54], the authors proposed Fast R-CNN in which, a technique called RoIPool (Region of Interest Pooling) is used that improves the training and testing speed and increases the accuracy for object detection. Later a team from Microsoft proposed an Faster-RCNN [55] architecture. They introduce Region Proposal Network (RPN) which is a kind of fully convolutional network (FCN) constructed by adding a few additional convolutional layers that predict object bounds and objectness (set of object classes vs. background) scores at each position. The RPN generates region proposals (multiple scales and aspect ratios), which are fed into Fast R-CNN for object detection. RPN and Fast R-CNN share their convolutional features which reduce the complexity, increases the speed and overall object detection accuracy. Lin et al. [57] present Feature Pyramid Networks (FPN), a multi-scale pyramidal hierarchy of deep convolutional network (ConvNet's), and creates feature pyramids having semantics at all levels, that can be used to replace featurized image pyramids with minimal cost (power, speed, or memory). He et al. [56] proposed a Mask Regional Convolutional Neural Network (Mask-RCNN), extending Faster R-CNN to pixel-level image segmentation. It added a branch (small FCN) on each RoI for predicting object mask in a pixel-to-pixel manner, in parallel with the existing branch for bounding box recognition (classification and regression). Faster R-CNN has a drawback of misalignment (pixel-to-pixel alignment) between network inputs and outputs. Mask-RCNN fixes this issue by replacing the RoI pooling layer with Region of Interest Alignment (RoIAlign), a quantization-free layer that preserves exact spatial locations as shown in Figure 6. Recently, Liu et al. [58] proposed network built on Mask-RCNN and FPN named Path Aggregation Network (PANet), boosting information flow in proposal-based instance segmentation framework.

Region proposal based neural networks have the advantage that object detection and segmentation can be achieved at the same time. Proposals are generated by algorithms ([59] provide an in-depth analysis) that are semantically meaningful and related to objects. It may contain an object class or several other classes that can help in determining the semantic labels. Furthermore, feeding the wrapped region proposals into a convolutional neural network for classification can reduce the computational cost.

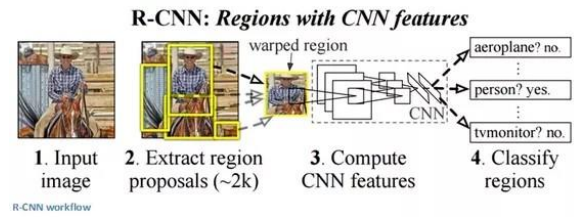

Table 3: Region Proposal based Methods

Category	Strategy / Structure	Corpus	Original Architecture	Testing Benchmark	Published On	Code Available
Regional Proposals	Regional Convolutional Neural Network (R-CNN) [52]	Regional proposal generator: Selective Search Method CNN: for extracting features from each region Set of class specific linear SVMs to score features.	AlexNet VGG-16	PASCAL VOC	October 22, 2014	YES
	Fast R-CNN [54]	Improvement in R-CNN Region of Interest (RoI) pooling layer.	VGG-16	PASCAL VOC	September 27, 2015	YES
	Faster R-CNN [55]	Region Proposal Network (RPN) Merge of RPN and Fast R-CNN.	VGG-16 FCN as RPN ZFNet	PASCAL VOC COCO	June 6, 2016	YES
	Mask R-CNN [56]	Region of Interest Alignment (RoIAlign): for pixel-to-pixel alignment	VGG-16 FCN as RPN ZFNet	Cityscapes, COCO	January 24, 2018	YES
	Feature Pyramid Network (FPN) [57]	Create feature pyramids having semantics at all levels, that can be used to replace featured image pyramids.	Fast/Faster R-CNN	COCO	April 18, 2017	YES
	Path Aggregation Network (PANet) [58]	Bottom up Path Augmentation Adaptive Feature Pooling: Fully connected Fusion:	Mask R-CNN / FPN	COCO, Cityscapes, Mapillary vistas	March 5, 2018	-

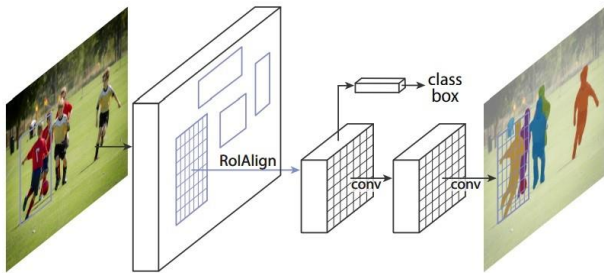

Figure 6: The framework of Mask R-CNN [56]

Recurrent Neural Network based Methods

Recurrent neural networks (RNNs) were genuinely introduced for dealing sequences [60, 61, 62]. Beside its accomplishments in handwriting and speech recognition, RNNs are very much successful in computer vision tasks (dealing with images). We have only reviewed network models that adopt RNN in 2D images (integrate the convolution layers with RNNs). The Recurrent neural network made up of Long- Short-Term Memory (LSTM) [63] blocks. RNN capability to learn long term dependencies from sequential data and ability to keep memory along the sequence makes it applicable in many computer vision tasks including semantic segmentation [64, 65] and scene segmentation and labeling [66, 67], based on using RNN CNN combination. **Table 4** shows RNN based methods.

Pinheiro et al. [68] proposed a convolutional neural network, which relies on a recurrent architecture (R -CNN). R -CNN is a sequence of shallow networks sharing same weights, at each instance using the downscaled input image and prediction maps from the previous instance of the network, and automatically learns to smooth its predicted labels. Heng et al. [66] pro-

posed the contextual RNNs for scene labeling. The proposed network can capture long-range dependencies (GIST, local and global features) in an image. These features (after upsampling) are fused via an attention model [67]. Amaiia et al. [75] present an encoder/decoder based recurrent neural network architecture for semantic instance segmentation. The proposed architecture much resembled FCN [77] architecture (encoder: feature extractor) using skip-connection, except with decoder part that is the recurrent network (convolutional LSTM [76]), predicting one instance (object in the image) at a time and output them. Byeon et al. [37] present a two-dimensional (2D) long-short term memory (LSTM) recurrent neural network for scene labeling. 2D LSTM network architecture consists of four LSTM blocks (it propagates surrounding contexts) and a feed forward layer (summing LSTM activations). This method is able to model long-range dependencies (both local and global) in image. Visin et al. [64] propose an RNN-based architecture for semantic segmentation codenamed **ReSeg** to model structured information of local generic features extracted from CNNs. The proposed model is a modified and extended version of ReNet [65]. The proposed recurrent layer is composed of multiple RNNs [73, 74] that sweep the image in both directions horizontally and vertically (output of hidden states), encoding local features, and providing relevant global information. ReNet layers are stacked on top of the output of a FCN. Figure 7 shows Reseg network architecture.

Shuai et al. [69] use graphical RNNs (Directed Acyclic Graph-Recurrent Neural Network or **DAG-RNN**) to model long-range contextual dependencies of local features in the image for semantic segmentation. They proposed a new class weighting function in order to improve the accuracy for recognition of non-frequent classes. Inspired by DenseNet [71], Fan and

Table 4: Recurrent Neural Network based Methods

Cetegory	Strategy / Structure		Corpus	Original Architecture	Testing Benchmark	Published on	Code Available
Recurrent Neural Network	Recurrent Convolution Neural Network (r CNN) [68]		Feed-Forward Approach: Models non-local class dependencies in a scene from the raw image (Extract contextual information).	LeNet	Stanford Background SIFT Flow	June 21, 2014	-
	Directed Acyclic Graph RNNs	DAG-RNNs [69]	Model the contextual dependencies of local features. Class Weighting Function that attends to rare classes.	VGGNet + RNN	SiftFlow, CamVid, Barcelona	November 23, 2015	-
		Dense Recurrent Neural Network (DD-RNN) [70]	Model contextual dependencies through dense connections Inspired by DenseNet [71]. Attention model to focus on relevant dependencies.	VGGNet + RNN	PASCAL Context, ADE20K, SiftFlow	January 23, 2018	-
		DAG-RNNs [72]	Model long-range semantic dependencies for graphical structured images. Class Weighting Function that attends to rare classes.	VGGNet + RNN	Sift Flow, Pascal Context COCO Stuff	June 6, 2017	-
		ReSeg: Recurrent Segmentation [64]	Modified ReNet [65] Recurrent Layer: Composed by multiple RNNs. Gated Recurrent Unit (GRU) [73] or LSTM [74]	ReNet + RNN	CamVid, Oxford Flower, Weizmann Horse	June 1, 2016	YES
		Multi-level Contextual Recurrent Neural Networks (MCRNNs) [66]	CRNNs encode three contextual cues (local, global and GIST). Attention model is adopted to improve effectiveness.	VGGNet + RNN	CamVid, KITTI, SiftFlow, Stanford-background, Cityscapes	January 23, 2018	-
		Two-Dimensional LSTM Network (2D-LSTM) [37]	Model long-range dependencies (Local: Pixel-by-Pixel and Global: Label-by-Label) in an image. LSTM blocks: Activation (surrounding contexts in all directions). Feedforward layer: Summing LSTM activations.	LSTM	Stanford Background SIFT Flow	June 7, 2015	-
		Recurrent model for semantic instance segmentation [75]	Encoder/Decoder based Recurrent Neural Network Encoder: Feature extractor Decoder: Convolutional LSTM [76], predicting one instance at a time	ResNet + Convolutional LSTM	Pascal VOC 2012, Cityscapes, CVPPP Plant Leaf Segmentation	March 22, 2018	YES

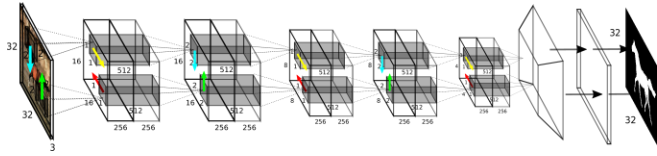

Figure 7: ReSeg Network [64]

bines semantic information from a deep coarse layer with ap-

Ling [70] proposed a DAG structured dense Recurrent Neural Network (DD-RNNs) architecture to model vast dependencies in images through dense connections. Recently, Shuai et al. [72] proposed a DAG-RNN network to model long-range semantic dependencies for graphical structured images (DAG-structured). Their proposed segmentation network consists of three modules: Local region representation (using pre-trained CNN), context aggregation (using DAG-RNN), and feature map upsampling (deconvolution network). They also proposed a class-weighted loss during training in order to overcome class imbalance issue or give attention to rare classes.

Recurrent neural network (RNN) can be very beneficial in semantic segmentation; it has recurrent connections (ability to retain previous information) and ability to capture context in an image by modeling long-range semantic dependencies for the image.

Upsampling / Deconvolution based Methods

Convolution neural network models have the ability to learn automatically high-level features via a layer-to-layer propagation with sacrificing the spatial information. One deep understanding is that spatial information lost during downsampling operation can be regained by upsampling and deconvolution. Second is to develop reconstruction technique for increasing spatial accuracy and refinement technique for fusing the features of a low and high level. **Table 5** shows Upsampling / Deconvolution based methods.

Noh et al. [79] used this idea and developed a network model by learning a deconvolution network. The convolution network reduces the size of activations through feed forwarding, and deconvolution network enlarges the activations through the combination of unpooling and deconvolution operations. Wang et al. [78] proposed an objectness-aware semantic segmentation framework (OA-Seg) using two networks, object proposal network (OPN), predicting object bounding boxes and their objectness scores, and lightweight deconvolutional neural network (Light-DCNN) for upsampling the feature maps to larger resolution. Long et al. [77] proposed first Fully Convolutional Network (FCN), and made breakthroughs in deep learning based semantic segmentation. FCN architectures have become the standard in semantic segmentation; most of the methods utilize FCN architecture. FCN converts the classification network [23, 27, 33] into fully convolutional network and produces a probability map for input of arbitrary size. FCN recovers the spatial information from the downsampling layers by adding upsampling layers to standard convolution network. They defined a skip architecture (shallow fine layer) that com-

pearance information to produce precise and in depth segmentation. The basic idea was to re-architect and fine-tune classification model (image classification) to learn efficiently from whole image inputs and whole image ground truths (prediction of semantic segmentation). This allows hence extending these classification models to segmentation, and improving the architecture with multi-resolution layer combinations. Figure 8 shows FCN architecture. Badrinarayanan et al. [80] present an

Figure 8: FCN: Segmentation Network [77]

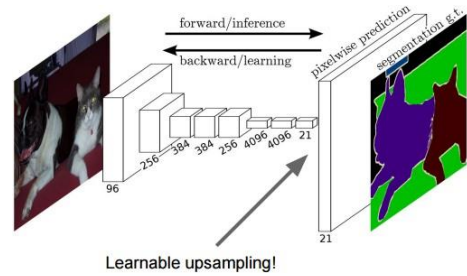

encoder decoder structure deep fully convolutional neural network called SegNet. The encoder network has the same topology as VGG [33] with no fully connected layers followed by a decoder network (from [93]) for a pixel-wise classification. SegNet obtains higher resolution than that in [77] by using set of decoders, each one corresponding to each encoder. One key feature of SegNet is that the information transfer is direct instead of convolving them. SegNet was one the best model to use when dealing with image segmentation problems specially scene segmentation tasks.

Ghiasi et al. [92] proposed a network called the Laplacian Pyramid Reconstruction and Refinement (LRR) since the architecture uses a Laplacian reconstruction pyramid [94]. The architecture uses low-resolution feature maps to reconstruct a coarse and low frequency segmentation map, and then refines this map by adding in higher frequency details derived from higher-resolution feature maps. Lin et al. [88] proposed a multi-path neural network named refinement network (RefineNet). RefineNet is an encoder decoder architecture inspired by residual connection design [34] and consists of three components; Residual convolution unit (RCU), Multi-resolution fusion and Chained residual pooling. Multi-path network exploits features

at multiple levels, it refines low-resolution features with concentrated low-level features in a recursive manner to produce high-resolution feature maps for semantic segmentation. Islam et al. [91] proposed a refinement structure architecture called Label Refinement Network (LRN). LRN learns to predict segmentation labels at multiple levels in the network and gradually refines the results at finer scale. LRN is an encoder decoder architecture and has supervision at multiple levels (at each stage of the decoder). Zhao et al. [87] proposed image cascade network (ICNet) which utilizes semantic information in low resolution along with details from high-resolution images efficiently. The network focuses on fusion of features from multiple layers. They proposed a cascade feature fusion (CFF) unit that fuses the low feature maps with high feature

Table 5: Upsampling / Deconvolution based Methods

Category	Strategy / Structure		Corpus	Original Architecture	Testing Benchmark	Published on	Code Available	
Unpooling of Low Level Features or Score Maps	Objectness-Aware Segmentation (OA-Seg) [78]		Object Proposal Network (OPN) generate object proposals Lightweight deconvolutional neural network (Light-DCNN) for upsampling	VGGNet	PASCAL VOC	October 15, 2016	-	
	Fully Convolutional DenseNet (FC-DenseNet) [51]		Built from a downsampling path, an upsampling path and skip connections. The main goal is to exploit the feature reuses	DenseNet	CamVid Gatech	October 31, 2017	YES	
	Encoder Decoder	ConvDeconvNet [79]	Convolution Network: Feature extractor Deconvolution Network: Shape Generator from the feature extractor	VGGNet	PASCAL VOC	May 18, 2015	YES	
		SegNet [80]	Obtain higher resolution by using a set of decoders one corresponding to each encoder.	VGGNet, DeconvNet	Cityscapes, KITTI, SUN RGB-D, CamVid	October 9, 2016	YES	
		Stacked Deconvolutional Network (SDN) [81]	SDN Unit: Efficient shallow deconvolutional network stack multiple SDN units one by one with dense connections.	DenseNet	PASCAL VOC CamVid, GATECH	August 16, 2017	-	
		Squeeze-SegNet [82]	DFire Module: Series of concatenation of expand module of SqueezeNet.	SqueezeNet SegNet	CamVid, Cityscapes	April 13, 2018	-	
		Fully Convolutional Network (FCN) [77]	Deep filter consisting (convolution, pooling, activation functions, deconvolution) layers. Upsampling: end-to-end learning by backpropagation from the pixel-wise loss.	Finetuning of AlexNet, VGGNet, GoogLeNet	Cityscapes, CIFAR10, KITTI, PASCAL VOC, CamVid, ADE20K, PASCAL Context, SYNTHIA, Freiburg Forest	March 8, 2015	YES	
		Skip Layer Architecture	Skip (Shallow fine layer) that combines semantic information from a deep, coarse layer with the appearance information to improve segmentation. FCN32s FCN16s FCN8s					
	Upsampling / Deconvolution	F e a t u r e F u s i o n	Fully Combine Convolutional Network (FCCN) [83]	Fusing and reusing feature maps Layer by Layer	FCN-VGG	CamVid, PASCAL VOC, ADE20K	January 4, 2018	-
			Semantic Motion Segmentation Network (SMSNet)[84]	FlowNet2 architecture[85] Semantic Segmentation component: AdapNet architecture Fusion component: combines both the motion and semantic features	FlowNet, AdapNet	Cityscapes, KITTI	September 1, 2017	YES
Dense Decoder Shortcut Connections [86]			Encoder: ResNeXt architecture A decoder is made up of blocks which generate semantic features maps. Multi-level fusion in single-pass inference	ResNeXt	Pascal VOC, Pascal Context, Pascal Person-Part, NYUD, CamVid	June 22, 2018	-	
Image Cascade Network (ICNet) [87]			Proposed a cascade feature fusion (CFF) unit	Modified PSPNet	Cityscapes	April 27, 2017	YES	
Reconstruction and Refinement		Encoder Decoder	Refine Network (RefineNet) [88]	Three Components 1. Residual convolution unit (RCU) 2. Multi-resolution fusion 3. Chained residual pooling	ResNet	Cityscapes, ADE20K, NYUDv2, SUN-RGBD, PASCAL VOC & Context	November 26, 2016	YES
			RGB-D Multi-level Residual Feature Fusion Network (RDFNET) [89]	Multi-modal feature fusion (MMF): the fusion of features (RGB and depth) Multi-level feature refinement: Refining feature	RefineNet	NYUDv2, SUN RGB-D	December 25, 2017	YES
			Gated Feedback Refinement Network (G-FRNet) [90]	Gate Unit: Combines low-resolution features and high-resolution features to produce contextual information. Refinement unit: Generate new label maps with larger spatial dimensions.	VGGNet	CamVid, PASCAL VOC, Horse-Cow Parsing	July 1, 2017	YES
			Label Refinement Network (LRN) [91]	Predicts semantic labels at several different resolutions in a coarse-to-fine fashion.	SegNet	CamVid, SUN RGB-D, PASCAL VOC	March 1, 2017	-

		Laplacian Pyramid Reconstruction and Refinement (LRR) [92]	Boundary mask "inset" used for localizing object boundaries. LRR-32x 16x and 8x layers	ResNet	Cityscapes, PASCAL VOC	July 30, 2016	YES
--	--	--	---	--------	---------------------------	------------------	-----

maps. Fu et al. [81] proposed Stacked Deconvolutional Network (SDN), inspired by [71]. The basic idea is stacking multiple shallow deconvolutional networks one by one in order to recover high-resolution prediction. Jegou et al. [51] proposed a Fully Convolutional DenseNet FC-DenseNet, the extension of [71] by adding an upsampling path and skipping connections to recover the full input resolution. Bilinski and Prisacariu [86] proposed an architecture following encoder decoder strategy. The encoder is based on ResNeXt architecture and decoder is made of blocks (dense decoder shortcut connections), which generate semantic feature maps and allow multi level fusion in single pass inference.

Yang et al. [95] proposed a fully combined convolutional network (FCCN) to improve the upsampling operation of FCN. The network follows layer-by-layer upsampling strategy, and after each upsampling operation the size of input feature map is doubled. They also proposed a soft cost function that further improves training. Recently in [83], they extend FCCN with a highly fused network. The proposed network has three major parts: feature downsampling, combined feature upsampling and multiple predictions. The fused network makes use of multiple scale feature information in low layers. Multiple soft cost functions are used to train the proposed model. Inspired by RefineNet, Park et al. [89] proposed RGB-D fusion network (RDFNet) for semantic segmentation. The proposed architecture is made of two feature fusion blocks: multi-modal feature fusion (MMF) to fuse features (RGB and depth) in different modalities, and multi-level feature refinement block to further refining feature for semantic segmentation. Islam et al. [90] proposed Gated Feedback Refinement Network (G-FRNet), an encoder-decoder style architecture. The proposed gated mechanism (Gate Unit) takes two feature maps one after another, i.e., low-resolution feature with larger receptive fields and high-resolution feature with smaller receptive fields, and combines them in order to produce contextual information. The feature maps with different spatial dimension generated by encoder network pass through gate unit before feeding to the decoder (feedback refinement network). The refinement network gradually refines the feature label maps. Recently, Nanfack et al. [82] proposed encoder-decoder based Squeeze-SegNet architecture. Encoder module is a SqueezeNet architecture [96] (using the fire module and removing the average pooling layer) inspired by SegNet which removes all fully connected layers of VGG. The squeeze-decoder module is the inversion of the fire module and convolutional layers of SqueezeNet.

Increase Resolution of Feature based Methods

Another type of method is to recover the spatial resolution by using atrous convolution [97] and dilated convolution [98] which can generate high-resolution feature maps for dense prediction. The dilated convolution hosts another parameter “dilation rate” (describing space between the values in a kernel) to convolution layer and it has the ability to expand the receptive field without losing resolution. **Table 6** shows increase resolution of feature based network models.

Chen et al. [97] from Google proposed a deep convolu-

tional neural network model named DeepLab. Instead of us-

ing deconvolution, they proposed Atrous ('Holes') convolution. The atrous algorithm was originally developed by Holschneider et al. [106] for computing undecimated wavelet transform (UWT). The DeepLab architecture is similar to the one in [77] with some modification like, converting fully-connected layers into convolutional layers, using stride of 8 pixels, skip subsampling after last two pooling layers, and modifying convolutional filters in the layers (increasing length of last three convolutional layers by 2x and the first fully connected layer by 4x) by introducing zeros. The proposed method is combined with fully connected conditional random fields (CRF) and is able to produce semantically accurate predictions and detailed segmentation maps efficiently. Yu and Koltun [98], developed a convolutional neural network module design for dense prediction using dilated convolutions to combine multiscale contextual information without losing resolution and analyzing rescaled images for semantic segmentation. This module can be plugged into existing architectures at any resolution. Figure 9 shows an example of dilation convolution with different dilation rates, which define spacing between the values in a kernel.

Figure 9: Dilated convolution with size of 3×3 with different dilation rates. (a) dilation rate = 1, receptive field = 3×3 (b) dilation rate = 2, receptive field = 7×7 .

Treml et al. [102] proposed an encoder decoder structured architecture (SQNet). The encoder is a modified SqueezeNet architecture [96] so-called "Fire", consisting of convolutional and pooling layers. The decoder is based on parallel dilated convolution layer. Wu et al. [105] present a fully convolutional residual network (FCRN), a new network for generating feature maps of any higher resolution, without changing the weights. They proposed a method to simulate a high resolution network with a low resolution network, and online bootstrapping method for training. In [99], Chen and his team proposed atrous spatial pyramid pooling (ASPP) module, consisting of multiple parallel atrous convolutional layers with different sampling rates to strongly segment objects at multiple scales. Figure 10 shows example of ASPP.

The proposed network is based on the state-of-art ResNet-101 [34] image classification DCNN. They combine the network with a fully connected Conditional Random Field (CRF) in order to improve the localization of object boundaries. Yu and Koltun [104] present another deep neural network named Dilated Residual Network (DRN), a residual network ResNet [34] like architecture, in which subset of interior subsamples

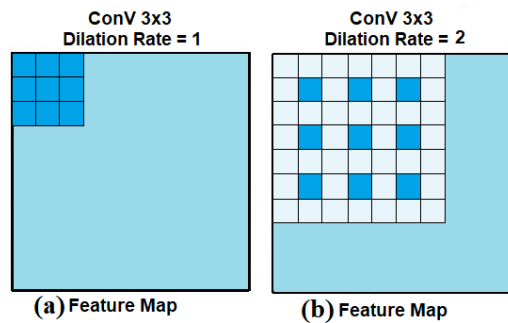

Table 6: Increase Resolution of Features based Methods

Category	Strategy / Structure		Corpus	Original Architecture	Testing Benchmark	Published on	Code Available
Increase Resolution of Features	Atrous Convolution	DeepLab [97]	Atrous ("Holes") Convolution	FCN-VGG	Cityscapes, PASCAL VOC	June 7, 2016	YES
		DeepLabV2 [99]	Atrous Spatial Pyramid Pooling (ASPP). Method effectively enlarge the field of view of filters to incorporate multi-scale context.	FCN-ResNet	Cityscapes, PASCAL VOC, COCO	May 12, 2017	YES
		DeepLabV3 [100]	Rethink Atrous Convolution Augment the Atrous Spatial Pyramid Pooling (ASPP).	DeepLabV2	Cityscapes, PASCAL VOC	December 5, 2017	-
		DeepLabV3+ [101]	Encoder Decoder Approach Xception [27]	DeepLabV3	PASCAL VOC	March 8, 2018	YES
	Dilated Convolution	Dilated Convolutions Module [98]	Rectangular Prism convolutional layers, with no pooling or subsampling for multi-scale context aggregation [34].	VGGNet	Cityscapes, PASCAL VOC	April 30, 2016	YES
		SQ Network [102]	Fire module: modified SqueezeNet [96] Parallel dilated convolution layer. Refinement module: SharpMask approach	SqueezeNet	Cityscapes	December 10, 2016	-
		Hybrid Dilated Convolution (HDC) [103]	Dense Upsampling Convolution (DUC) by TuSimple.	ResNet + DUC	KITTI, PASCAL VOC	November 9, 2017	YES
		Dilated Residual Network (DRN) [104]	Replacing dilated convolutions layers into ResNet model.	ResNet	Cityscapes	May 28, 2017	YES
	Fully Convolutional Residual Network (FCRN) [105]		Method to simulate a high resolution network with a low resolution network. Enlarge the field-of-view (FoV) of features. Online bootstrapping method for training.	ResNet + FCN DeepLab	Cityscapes, PASCAL VOC	April 15, 2016	-

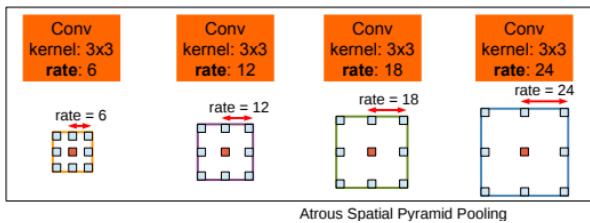

Figure 10: Atrous Spatial Pyramid Pooling (ASPP) [99]

layers are replaced by dilation [98] to increase the resolution. The subsampling removing means removing striding from some of the interior layers, increasing downstream resolution and reducing the receptive field in subsequent layers. They also propose an approach to remove the gridding artifacts introduced by dilation (degridding), which further improves the performance. Later, Chen et al. [100] revisited atrous convolution and proposed a new system network called DeepLab V3. They designed new modules in which atrous convolution works in cascade or in parallel manner (spatial pyramid pooling as shown in Figure 11 (a)) to capture multi-scale context by adopting multiple atrous rates, and used batch normalization to train. Their main idea was to duplicate several copies of the last block in ResNet [34] and arrange them in cascade manner. Wang et al. [103] proposed a method named design dense upsampling convolution (DUC). The basic idea of DUC is to transform the label

map into a smaller label map with multiple channels (dividing the label map into equal subparts having same height and width as the incoming feature map). They also proposed a hybrid dilated convolution (HDC) framework in the encoding phase that effectively enlarges the receptive fields of the network to aggregate global information. Recently in [101] the DeepLab V3+, which is the extended version of DeepLab V3 was presented. Inspired by [107], the authors proposed a decoder module, in which the encoder features are upsampled by a factor of 4 instead of 16 as in [100], then are concatenated with the corresponding low-level features from network backbone having the same spatial resolution as shown in Figure 11 (b). They adopted the Xception model [31] and applied depth-wise separable convolution (to reduce computation complexity) to both Atrous Spatial Pyramid Pooling (ASPP) and decoder modules.

Compared to regular convolution with larger filters, atrous convolution allows to effectively enlarging the field of view of filters without increasing the number of parameters or the amount of computation. Dilated convolution is a simple yet powerful alternative to deconvolutional in dense prediction tasks.

Enhancement of Features based Methods

Enhancement of feature based methods include extraction of feature at multi-scale or from a sequence of nested regions. In deep networks for semantic segmentation, CNNs are applied to image square patches, often called kernel of fixed size

Table 7: **Enhancement of Features based Mtheds**

Category	Strategy / Structure	Corpus	Original Architecture	Testing Benchmark	Published on	Code Available	
Enhancement of Features	Multi-Scale Network [108][109]	Multi-scale Convolutional Network extract dense feature vectors that encode regions of multiple sizes centered on each pixel. Multiple post-processing methods for labeling.	LeNet	Sift Flow, Barcelona, Stanford Background	October 24, 2012	-	
		Learn multi-scale features using the image depth information.	LeNet	NYUDv2	March 14, 2013	-	
	Multi-scale Patch Aggregation (MPA) [110]	Multi-scale Patch Generator: Cropping corresponding feature grids from Image, and aligning these grids to improve the generalization ability. A strategy is proposed to assign the classification and segmentation labels to the patches.	VGG-16	PASCAL VOC, COCO	June 1, 2016	-	
	Hypercolumns [111]	Hypercolumn Classifier: Pixel Classification.	Tested with R-CNN	PASCAL VOC	November 22, 2014	-	
	DeepLab Attention Model [67]	Learns to weight the multi-scale features according to the object scales presented in the image, then for each scale outputs a weight map which weights feature pixel by pixel.	DeepLab	PASCAL VOC, COCO	June 1, 2016	-	
	Pyramid Scene Parsing Network (PSPNet) [112]	Pyramid pooling module consists of the large kernel pooling layers for global scene prior construction	ResNet Dilated FCN	Cityscapes, ADE20K, PASCAL VOC	April 25, 2017	YES	
	Cascade Dilated Convolutions Network [113]	Cascading dilated convolutions (consecutive layers connection) to extract dense features. Feature fusion through Maxout Layer (Maxout Network [114])	Dilated-ResNet FCN-VGG	PASCAL VOC	February 21, 2018	-	
	Context Contrast Local (CCL) Model [115]	CCL: Consists of several chained context-local blocks to make multi-level context contrasted local features. Gate Sum: Fusion strategy to aggregate appropriate score maps.	ResNet	Pascal Context, SUN-RGBD, COCO Stuff	June 18, 2018	-	
	Feature Extraction from sequence of nested regions	Cascaded Feature Network (CFN) [116]	Context-aware Receptive Field (CaRF): to aggregate convolutional features of local context into strong features.	FCN + RefineNet	NYUDv2, SUN-RGBD	December 25, 2017	-
		Zoom Out [117]	Zoom out features construction using superpixels (SLIC Method) from different levels of spatial context Local Level: Superpixel itself Distant Level: Regions large enough to cover fractions of an object or entire object. Scene Level: Entire scene Combining features across levels rather than predicting.	VGG-16	PASCAL VOC	December 2, 2014	-

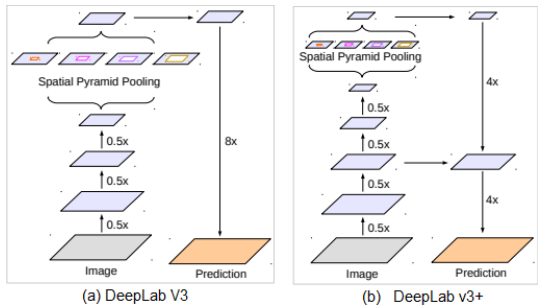

Figure 11: DeepLabV3 and DeepLabV3+ [101]

centered at each pixel, labeling each pixel by observing small region around it. The network covering large and wide context (size of receptive field) is essential for better performance, which can be achieved but with increase the computational complexity. Multi-scale feature extraction or extraction from a sequence of nested region strategies can be taken in to account while ensuring computational efficiency. **Table 7** shows enhancement of features based network models. Alvarez et al. [107] propose a network algorithm to learn local features at multi-scales and multi-resolutions using different kernel sizes. The features are fused using weighted linear combination (features of each class with different weight) learned at the same time (offline) directly from the training data. Farabet et al. [108] proposed a method that extracts multiscale features vectors from the image pyramid (Laplacian pyramid version of the input image) using the multi-scale convolutional network shown in Figure 12. Each feature vector encodes regions of multiple sizes centered on each pixel location, covering wide context.

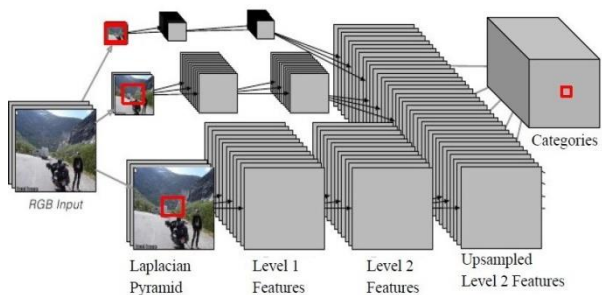

Figure 12: Multiscale CNN for scene parsing [108]

Coupric et al. [109] adopted a similar approach, and proposed a convolutional network to learn multi-scale features using image depth information. Liu et al. [110] proposed the strategy named Multi-scale Patch Aggregation (MPA). The proposed network generates multi-scale patches for object parsing, achieves segmentation and classification for each patch at the same time and aggregates them to infer objects. Hariharan et al. [111] proposed a pixel classification method (multiple levels of abstraction and scale), Hypercolumn. The basic idea is to extract feature information from earlier layers and last layers of the CNN to allow precise localization and high semantics, and

then resizing each feature map with bilinear interpolation. Further some or all of the features are concatenated into a single vector for every location.

Mostajabi et al. [117] present a feedforward classification method named Zoom-Out using Superpixels (SLIC [118]). It extracts features from different levels (local level: superpixel itself; distant level: regions large enough to cover fractions of object or entire object; scene level: entire scene) of spatial context around the superpixel to contribute to labeling decision at that superpixel. Then it computes feature representation at each level and combine all the features before feeding them to a classifier. Chen et al. [67] proposed attention based model, with ability to choose each time, which part of the input to look at in order to perform the task. The proposed attention model learns to weight the multi-scale features according to the object scales presented in the image (e.g. the model learns to put large weights on features at a coarse scale for large objects). Then for each scale, the attention model outputs a weight map which weights features pixel by pixel, and the weighted sum of FCN-produced score maps across all scales is then used for classification.

Zhao et al. [112] present pyramid scene parsing network (PSPNet) for semantic segmentation, which allows multi-scale feature ensembling. They have introduced the pyramid pooling module consisting of large kernel pooling layers shown in Figure 12, which empirically proves to be an effective global contextual prior, containing information with different pyramid scales and varying among different sub-regions. It concatenates the feature maps with the up sampled output of parallel pooling layers. The idea is also called intermediate supervision. The representations are fed into a convolution layer to get the final per-pixel prediction. Figure 13 shows PSPNet Architecture.

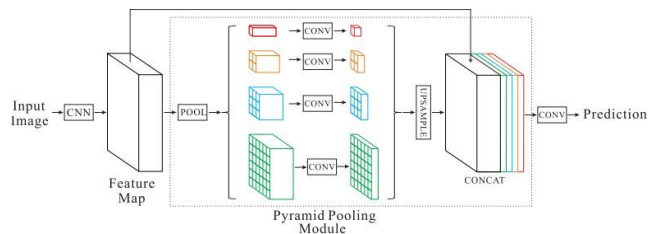

Figure 13: Pyramid Scene Parsing Network (PSPNet) [112]

Vo and Lee [113] proposed a deep network architecture with multi-scales dilated convolution layers to extract multi scale features from multi resolution input images. The basic idea consists of cascading dilated convolutions (consecutive layers connection), each layer, with a higher rate than the previous one, achieves denser feature maps. All feature maps are then sized to same resolution and fused into a Maxout layer [114] to get most driven and leading features from all feature maps. Lin et al. [116] proposed a network called cascaded feature network (CFN). It utilizes depth information, dividing the image into layers representing visual characteristic of objects and scenes (multi-scene resolutions). Proposing context-aware receptive field CaRF (superpixel based), aggregates convolutional features of local context into strong features. The CaRF gener-

ates contextual representations, large superpixels for low scene-resolution regions and finer super pixels for regions with higher scene-resolution. Recently, Ding et al. [115] proposed a context contrasted local (CCL) model to obtain multi-scale features (both context and local). Instead of using simple sum, they proposed Gate-Sum fusion strategy to aggregate appropriate score maps, which allows a network to choose better and more desired scale of features.

Several methods aimed to capture multi-scale features, higher-layer feature contains more semantic meaning and less location information. Combining the advantages of multi-resolution images and multi-scale feature descriptors to extract both global and local information in an image without losing resolution improves the performance of the network.

Semi and Weakly Supervised Concept

The CNN's are becoming deeper and deeper by increasing the depth and width (the number of levels of the network and the number of units at each level). Deep CNN requires large-scale dataset and massive computing power for training. Collecting labeled dataset manually is time consuming and requires enormous human efforts. To comfort these efforts, semi or weakly supervised methods are applied using deep learning techniques. **Table 8** shows semi and weakly supervised network models used for semantic segmentation.

Work by Pathak et al. [119] is to be the first considering the fine-tuning of CNN pre-trained for object recognition, using image-level labels, within a weakly supervised segmentation context. They introduced a fully convolutional network method, which relies on a Multiple Instance Learning (MIL-FCN) [138], i.e., learn pixel-level semantic segmentation from weak image level labels indicating the presence or absence of an object. They proposed a multi-class pixel-level loss inspired by the binary MIL scenario. Pinheiro et al. [120] proposed a weakly supervised approach to produce pixel level labels from image-level labels using Log-Sum-Exp (LSE) [121] method, which assigns the same weight to all pixels of the image during the training. Papandreou et al. [123] presented a weakly and semi-supervised learning method using weak annotations, either alone or in combination with small number of strong annotations. They developed a method called Expectation Maximization (EM) for training DCNN from weakly annotated data. Hong et al. [122] proposed a semi-supervised method (DecoupledNet), which uses two separate networks, one for classification (classifies the object label) and the other for segmentation (to obtain figure-ground segmentation of each classified label). Dai et al. [135] propose a method based on bounding box annotations (BoxSup). The unsupervised region proposal method (selective search [53]) is used to generate segmentation masks, and these masks are used for training convolutional network. The proposed BoxSup model, trained with a large set of boxes, increases the object recognition accuracy (the accuracy in the middle of an object), and improves object boundaries. Khoreva et al. [139] proposed a box-driven segmentation technique for semantic segmentation, which generates input labels for train-

ing from the bounding box annotations using Grab Cut-like al-

gorithm [140] without modifying the training procedure. Luo et al. [125] present a weakly and semi-supervised dual image segmentation (DIS) learning strategy, which performs segmentation (capturing the accurate object classes), and reconstruction (accurate object shapes and boundaries). The idea is to predict tags, label maps from an input image, and perform reconstruction of images using predicted label maps.

Saleh et al. [129] proposed weakly supervised segmentation network with built-in foreground/background prior. The main idea is to extract the localization information directly from the network itself (extracting foreground/background masks). Later in [130], they extended their work to obtain multi-class (class-specific) masks by the fusion of foreground / background ones with information extracted from a weakly supervised localization network inspired by [141]. Saito et al. [131] present a method that uses the feature maps extracted from a pre-trained dilated ResNet having built-in priors for semantic segmentation. They proposed a superpixel clustering method to generate road clusters (to select largest cluster at the bottom half of image), that are considered as the label to train CNN for segmentation. Barnes et al. [128] develop a weakly supervised method for autonomous driving applications for generating a large amount of labelled images (from multiple sensors and data collected during driving) containing path proposals without any manual annotation. Ye et al. [134] proposed a method for learning convolutional neural network models from images with three different types of annotations, i.e., image-level labels for classification, box-level labels for object detection and pixel-level labels for semantic segmentation. They proposed an annotation-specific loss module (with three branches, each branch with a different loss function), which is designed to train the network for each of the three different annotations.

Souly et al. [126] proposed a semi-supervised semantic segmentation method using adversarial learning inspired by Generative Adversarial Networks (GANs) [142]. Later, Hung et al. [154] proposed a similar approach which consists of two sub nets; segmentation net (to generate class probability maps) and discriminator net (to generate spatial probability maps with both labeled and unlabeled data). Wei et al. [133] presented a weakly and semi supervised approach by using multiple dilated convolutions. They proposed augmented classification network with multi-dilated convolutional (MDC) blocks that generate dense object localization maps, which are utilized for semantic segmentation in both weakly and semi supervised manner. Huang et al. [124] proposed a weakly supervised network, which produces labels using the contextual information within an image. They proposed a seeded region growing module to find small and tiny discriminative regions from the object of interest using image labels to generate complete and precise

pixel level labels, which are used to train semantic segmentation network. Wei et al. [143] proposed a Simple to Complex (STC) network, a weakly supervised approach using image-level annotations. The basic idea is first to learn from simple images (to generate saliency maps using discriminative regional feature integration (DRFI)), and then apply learned network to the complex images (to generate pixel-level segmentation masks of complex images) for semantic segmentation.

Table 8: Semi and Weakly Supervised based Methods

Category	Strategy / Structure		Corpus	Original Architecture	Testing Benchmark	Published on	Code Available	
Weakly and Semi Supervised	Image Level Labels	Multiple Instance Learning (MIL-FCN) [119]		Multi-class pixel-level loss inspired by the binary MIL scenario.	VGG	PASCAL VOC	April 15, 2015	-
		Aggreg-LSE [120]		An approach to produce pixel-level labels from image-level labels using Log-Sum-Exp (LSE) [121].	VGG	PASCAL VOC	June 7, 2015	-
		Utilization of Heterogeneous Annotations	DecoupledNet [122]	Classification Network: Identifies labels Segmentation Network: Produces pixel-wise figure-ground segmentation corresponding to each identified label. Bridging layers connecting the two Networks (Decoupling).	VGG	PASCAL VOC	June 17, 2015	YES
			WSSL [123]	Expectation Maximum (EM) Module for fast training under both weakly and semi-supervised settings.	DeepLab	Cityscapes, PASCAL VOC	December 7, 2015	YES
		Simple to Complex (STC) [124]		A progressively training strategy is proposed by incorporating simple-to-complex images with image-level labels.	VGG + DeepLab	PASCAL VOC	November 1, 2017	-
		Dual Image Segmentation DIS [125]		Segmentation: Predict tags and label maps from the image (captured the accurate object classes). Reconstruction: The reconstruction of images using predicted label maps (accurate object shapes and boundaries).	ResNet	PASCAL VOC	December 25, 2017	-
		Adversarial Learning	SW-GAN [126]	Generative Adversarial Network framework which extends the typical GAN to a pixel-level prediction.	VGG	PASCAL VOC, SiftFlow, StanfordBG, CamVid	March 28, 2017	-
			Semi-Adv [127]	Propose a fully convolutional discriminator that learns to differentiate between ground truth label maps and probability maps of segmentation predictions.	DeeplabV2	PASCAL VOC, Cityscapes	February 22, 2018	YES
		Segmenting Path Proposals [128]		Weakly-supervised approach to segmenting proposed paths for a road vehicle Method for generating a large amount of labeled images without any manual annotation.	SegNet	KITTI, Oxford	November 17, 2017	-
		Built-in Feature Extraction Approach	Fg/Bg Masks [129]	Weakly-supervised segmentation network with built-in Foreground/Background Prior "Information extracted from a pre-trained network".	VGG-16	PASCAL VOC	September 2, 2016	-
			Multi-Class Mask [130]	Foreground/background mask combined to generate the class-specific mask Multi-Class Prior.	VGG-16	PASCAL VOC	June 6, 2017	-
			Superpixel Clustering Method [131]	Pre-trained Dilated ResNet for Feature extraction SuperPixel Align Method (FH Superpixel) Road Feature Clustering (K-Means).	DRN + SegNet	Cityscapes	November 16, 2017	-
		Deep Seeded Region Growing (DSRG) Network [132]		Utilize the Seeded Region Growing mechanism to generates pixel-level labels.	VGG	PASCAL VOC, MS COCO	February 1, 2018	YES
		Multi-Dilated Convolutional (MDC) [133]		Multi-Dilated Convolutional (MDC) Blocks: Produce dense object localization maps which can be utilized for segmentation both in weakly and semi-supervised manner.	VGG + DeepLab	PASCAL VOC	May 28, 2018	-
		Multi-Level Labels	Diverse Supervision	Annotation-Specific FCN [134]	Annotation-Specific Loss Module Image-level labels for classification Box-level labels for object detection Pixel-level labels for semantic segmentation	FCN	PASCAL VOC	February 1, 2018
Bounding Box	Boxsup [135]		The semi-supervised approach based on bounding box annotations Uses SelectiveSearch [136]: to generate segmentation masks. Iterate between an automatically generating region proposals and training convolutional network	FCN	PASCAL VOC, CONTEXT, MS COCO	May 17, 2015	-	
	MCG-GrabCut+ [137]		A weakly supervised approach based on bounding box annotations Uses GrabCut+ Approach [132]: to estimate object segment.	VGG + DeepLab	PASCAL VOC, MS COOC	November 9, 2017	YES	

VGG, RFC Dilated), learning spatio-temporal features with less

Semi and weakly supervised learning aims to reduce the load for full annotation. These methods improved learning performance using weak annotations in the form of image-level labels (information about which object classes are present) and bounding boxes (coarse object locations).

Spatio-Temporal based Methods:

In this section, we aim to investigate the deep convolutional networks that use spatial information along with temporal information for semantic segmentation.

In a video, frames are associated with each other and have temporal information (i.e., features of continuous sequences of frames) that can be useful for interpreting a video semantically. Spatio-temporal structured prediction can prove useful in both supervised and semi-supervised manner. **Table 9** shows Spatio-Temporal based network models for semantic segmentation.

Several methods are proposed in the combination of Recurrent Neural Networks (RNN) and Convolutional Neural Network (CNN) for video segmentation. Fayyaz et al. [145] presented a full convolutional network Spatio-Temporal Fully Convolutional Network (STFCN) employing spatial and temporal features. They proposed spatio-temporal module that takes the advantage of LSTM in order to define temporal features. The spatial feature maps of the region in single frame fed into LSTM, infers a relation with spatial features of equivalent regions in frames before that frame. Further, spatial and temporal information fed into dilated convolution network ([98] with minor modifications) for upsampling and are fused (summing operation) for semantic predictions. He et al. [146] proposed Spatio-temporal data-driven pooling model (STD2P), which is method to integrate multi-view information by using super pixels and optical flow. The goal of multi-view semantic segmentation is to make use of the potentially richer information from different views with better segmentations than single view. Qiu et al. [148] proposed 2D/3D FCNs based architectural model named deep spatio-temporal fully convolutional networks (DST-FCN), that utilizes spatial and temporal dependencies among pixels and voxels. The proposed architecture is a two stream network, Sequential frame stream, (2DFCN for spatial and ConvLSTM for temporal information), and clip stream, (3DFCN based on C3D [152] developed on voxel level). Pavel et al. [153] present a recurrent convolutional neural network model utilizing spatial and temporal information for processing image sequences. Yurdakul et al. [154] proposed a network that combines color and depth information in RGBD videos for semantic segmentation using convolutional and recurrent neural network frameworks.

Some architectures are based on Gated Recurrent Architectures to overcome gradients problem. Ballas et al. [155] used a term percepts (visual representations extracted from different levels of DCN) to capture spatial-temporal feature information in the video using gated-recurrent-unit recurrent networks. Siam et al. [149] present a fully convolutional network based on gated recurrent architecture (RFCN). Three different architectures were used following two approaches, conventional recurrent units (RFCLeNet) and convolutional recurrent units (RFC

number of parameters. Nilsson et al. [151] present Gated Re-current Flow Propagation network. They proposed Spatio-Temporal Transformer Gated Recurrent Unit (STGRU), combining the strength of spatial transformer (for optical flow warping) with convolutional gated architecture (to adaptively propagate and fuse estimates). Shelhamer et al. [144] proposed a network named Clockworks, which is a combination of FCN and clockwork recurrent network [156], grouping the layers of the network into stages with different rates (either fixed clock rate or adaptive clock) and then fusing them via skip connections. Saleh et al. [150] proposed a weakly supervised framework for video semantic segmentation that treats both foreground and background classes equally. The basic idea is to manage multiple foreground objects and multiple background objects equally. They propose an approach to extract class-specific heatmaps from classifier that localizes the different classes for both without pixel level or bounding box annotations. Kundu et al. [147] proposed a model to optimize the feature space used by the fully connected conditional random field for spatio-temporal regularization. Chandra et al. [157] proposed a Video Gaussian Conditional Random Field approach for spatio-temporal structured prediction, which is an extension of [158]. The FCN network obtains unary (class score per-pixel), spatial pairwise and temporal pairwise terms, which are fed into G-CRF module that performs inference (linear system) to obtain the final prediction.

Methods using CRF / MRF:

Semantic segmentation involves pixelwise classification and such pixelwise classification often produces unsatisfactory results (poor, incorrect and noisy predictions) that are irreconcilable with the actual visual features of the image [159].

Markov random field (MRF) and its variant Conditional Random Fields are classical frameworks that are widely used to overcome these issues. They express both unary term (per-pixel confidence of assigning labels) and pairwise terms (constraints between adjacent pixels). CNNs can be trained to model unary and pairwise potentials in order to capture contextual information. The context provides important information for scene understanding tasks such as spatial context which provides semantic compatibility/incompatibility relation between objects, scenes and situations. CRFs can be a post processing or end-to-end, to smooth and refine the pixel prediction in semantic segmentation. They combine class scores from classifiers with the information captured by the local interactions of pixels and edges or superpixels. **Table 10** shows network models using CRF.

Krahenbuhl et al. [160] proposed a fully connected CRF (DenseCRF) model, in which pairwise edge potentials are defined by a linear combination of Gaussian kernels.

The method is based on mean field approximation, message passing is performed using Gaussian filtering techniques [161]. Methods [79,97, 123, 135, 129, 139, 133, 150] coupled fully connected CRF with their proposed DCNNs to produce accurate predictions and detailed segmentation maps for improving performance. Zheng et al. [162] formulate mean-field inference algorithm for the dense CRF with Gaussian filtering technique as recurrent

Table 9: Spatio-Temporal based Methods

Category	Strategy / Structure	Corpus	Original Architecture	Testing Benchmark	Published on	Code Available
Spatio-Temporal	Clockwork FCN [144]	Clockworks: clock signals that control the learning of different layers with different rates	FCN Clockwork RN	Youtube-Objects, NYUD, Cityscapes	August 11, 2016	YES
	Spatio-Temporal FCN [145]	Spatial-Temporal Module embedding into FCN LSTM to define relationships between image frames	FCN	Camvid NYUDv2	September 2, 2016	YES
	Spatio-Temporal Data-Driven Pooling (STD2P) [146]	Incorporate superpixels and multi-view information into convolutional networks	FCN	NYUDv2 SUN 3D	April 26, 2017	-
	Feature Space Optimization (FSO) [147]	Optimize the mapping of pixels to a Euclidean feature space used by DenseCRF for spatio-temporal regularization	VGG Dilation	CityScapes, Camvid	December 12, 2016	YES
	Deep Spatio-Temporal FCN (DST-FCN) [148]	Learn spatial-temporal dependencies through 2D FCN on pixels and 3D FCN on voxels	VGG C3D	A2D, CamVid	October 5, 2017	-
	Gated Recurrent FCN [149]	Implementation of three gated recurrent architectures RFC-LeNet: Conventional Recurrent Units. RFC-VGG and RFC-Dilated: Convolutional Recurrent Units.	FCN	SegTrack V2, Davis, Cityscapes, SYNTHIA	November 21, 2016	-
	WSBF[150]	Weakly-Supervised Two-stream Network. One stream takes image, and other optical flow to extract the features. RFC-VGG and RFC-Dilated: Convolutional Recurrent Units.	VGG	Cityscapes, CamVid, YouTube-Objects	August 15, 2017	-
Gated Recurrent Flow Propagation (GRFP) [151]	Spatio-Temporal Transformer Gated Recurrent Unit (STGRU) Combining spatial transformer with convolutional-gated architecture.	Dilation LRR	CityScapes, Camvid	October 2, 2017	-	

neural network (CRF-RNN), that performs CRF-based probabilistic graphical modelling for structured prediction. **Figure 14** shows CRF as RNN.

posed a Gaussian Conditional Random Field (G-CRF) mod-

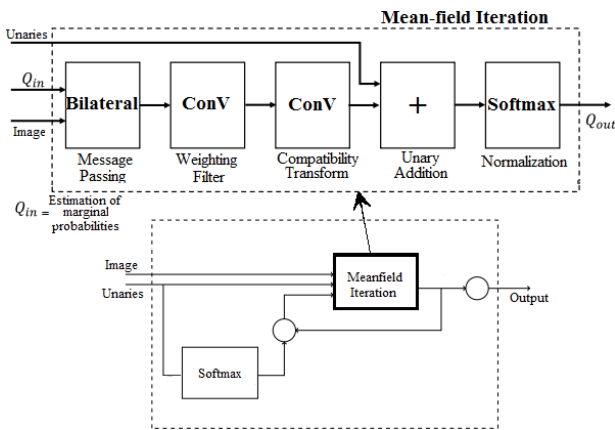

Figure 14: CRF as a recurrent Neural Network [162]

Vemulapalli et al. [163] proposed a model named Gaussian Mean Field (GMF) network that models unary potentials, pairwise potentials and Gaussian CRF inference for the task of semantic segmentation. In the proposed network, output of each of the layer is closer to maximum a posteriori probability (MAP) estimated to its input. Chandra et al. [158] pro-

ule using a quadratic energy function that captures unary and pairwise interactions. Lin et al. [169] propose a model Con- text CNN CRF jointly learning CNN and CRFs. They formu- late CRF with CNN pairwise potential to capture contextual relationship between neighboring patches and sliding pyramid pooling (multi-scale image network input) for capturing patch-background context that can be combined to improve the seg- mentation. Instead of learning the potentials, [168] proposes a method that learns CNN message estimators for the mes- sage passing inference for structured Conditional Random Field (CRFs) predictions. Teichmann et al. [164] proposed convolu- tional CRFs (ConvCRFs) method that reformulates the message passing inference in terms of convolutions.

Some methods employed higher-order potentials (based on object detection or superpixels) modelled as CNN layers when using mean field inference and effective in improving seman- tic segmentation performance. Arnab et al. [165] proposed a method in which CRF models unary and pairwise potentials together with high-order potentials object detector (to provide semantic cues for segmentation) and superpixel (having label consistency over regions) in an end-to-end trainable CNN. Shen et al.[166] proposed joint FCN and CRF model (SegModel) that integrates segmentation specified features, which consti- tutes high order context and boundary guidance (bilateral-filteringbased CRF) for semantic segmentation. Liu et al. [167] pro-posed Deep Parsing Network (DPN), which models unary term and pairwise terms (i.e., high-order relations and mixture of la-

Table 10: Methods using CRF/MRF

Category	Strategy / Structure		Corpus	Original Architecture	Testing Benchmark	Published on	Code Available	
CRFs / MRFs	Fully Connected-CRF (DenseCRF) [160]		Based on mean field approximation, message passing performed using Gaussian filtering techniques [161].	ResNet	PASCAL VOC	May 15, 2018	Yes	
	CRF-RNN [162]		Multiple Mean-field Iterations. Interpretation of dense CRFs as Recurrent Neural Networks (CRF-RNN) combined with CNN.	FCN	PASCAL VOC Cityscapes	April 13, 2016	-	
	Gaussian Conditional Random Field (GCRF)	Gaussian Mean Field (GMF) Network [163]	GMF Network: Performing Gaussian mean field inference.	DeepLab	PASCAL VOC ImageNet	June 26, 2016	Yes	
	Quadratic Optimization (QO) [158]		Quadratic Optimization (QO) module	FCN	PASCAL VOC	November 29, 2016	-	
	Convolutional-CRF (ConvCRF) [164]		Inference in terms of convolutions.	ResNet	PASCAL VOC	May 15, 2018	Yes	
	Incorporating Higher Order potentials	Higher-order CRF [165]	Object-detection based potentials: Provide Semantic cues for segmentation. Superpixel-based potentials: Encourage label consistency over regions.	CRF-RNN	PASCAL VOC, Context	July 29, 2016	-	
		Structured Patch Prediction (SegModel) [166]	Integrate segmentation specified features, high order context and boundary guidance.	FCN	PASCAL VOC Cityscapes ADE20K	November 9, 2017	-	
	Deep Parsing Network (DPN) [167]		Models Unary term and Pairwise terms in single CNN.	VGG	PASCAL VOC	September 24, 2015	-	
	Adelaide	Learning Messages [168]		CNN message estimators for the message passing inference.	VGG-16	PASCAL VOC	September 8, 2015	-
		Bounding-box Detection	Adelaide Very Deep FCN [136]	Hough transform based approach Online bootstrapping method for training.	FCRN	PASCAL VOC	May 23, 2016	-
Context CNN CRF [169]		Patch-patch context: Formulate CRFs to capture contextual relationship between neighboring patches Patch-background context: Sliding Pyramid Pooling.	VGG-16	PASCAL VOC NYUDv2 Pascal Context Siftflow	June 6, 2016	-		
incorporate the depth information	Depth-sensitive fully-connected Conditional Random Field (DFCN-DCRF) [170]	Fully-connected CRFs with RGB information and depth information.	FCN	SUN-RGBD	October 4, 2017	-		

bel contexts) in single CNN that achieve high performance by extending the VGG network, and adding some layers for modeling pairwise terms. Jiang et al. [170] utilize the depth information as complementary information into conditional random fields. They proposed depth sensitive fully connected conditional random field combined with a fully convolutional network, (DFCN-DCRF). The basic idea is to add the depth information into dilated-FCN and fully connected CRF to improve accuracy for semantic segmentation.

CRF inference with deep convolutional neural network improves pixel-level label predictions by producing sharp boundaries and dense segmentation. Several methods learn arbitrary potentials in CRFs. It has been used as post processing, end-to-end fashion, formulated as RNN and incorporated as module in existing neural network.

Alternative to CRF:

Integrating conditional random field into original architecture is a difficult task due to additional parameters and highly computational complexity at training. Moreover, the majority of CRFs uses hand constructed color-based affinities that may lead to spatial false predictions. Several methods have been proposed to overcome these issues and can be used as alternate to CRFs. **Table 11** shows network models alternate to CRFs.

Bertasius et al. [173] proposed a FCN architecture named Boundary Neural Field (BNF) to predict semantic boundaries and produce semantic segmentation maps using global optimization. The BNF combines the unary potentials (prediction by FCN) and pairwise potentials (boundary-based pixel affinities) from the input RGB image in a global manner. The basic idea is to assign pixels to the foreground and background labels for each of the different object classes and apply constraint relaxation. Later in [176], they proposed Convolutional Random Walk Network (RWN) addressing same issue, model based on random walk method [177]. The network model predicts semantic segmentation potentials and pixel level affinities, and combines them through proposed random walk layer that applies spatial smoothing predictions.

Jampani et al. [171] propose a network based on Gaussian bilateral filter [178], named bilateral neural network (BNN). Bilateral filter inference in fully connected CRF [160] (by replacing Gaussian potentials with bilateral convolution) to learn pairwise potentials of fully connected CRF. Barron et al. [172] propose edge-aware smoothness algorithm using bilateral filtering technique name the bilateral solver. Peng et al. [175] proposed a residual-based boundary refinement model, Global Convolutional network (GCN), for semantic segmentation. They proposed boundary refinement block (FCN structure without fully connected and global pooling layers) to model the boundary alignment as a residual structure. Chen et al. [174] proposed a model with domain transform (DT) module as a substitute to CRF, an edge preserving filtering method. The model consists of three modules. The first module produces semantic segmentation score prediction based on DeepLab. The second module named Edge Net, predicts edge features from midway layers

and the third module is an edge-preserving filter named Domain Transform (recursive filtering), proposed in [179].

Several methods have been proposed that can be used as alternative to CRF with the advantage of fast and less number of parameters. Bilateral filtering techniques can be useful tool in the construction of deep learning frameworks.

Figure 15 gives an overview to the readers to have good understanding of the categorization of different methods for semantic segmentation.

3. Datasets and Evaluation for Deep Learning techniques

One of the hardest problem for any segmentation systems based on deep learning techniques is the collection of data in order to construct suitable dataset. There are four possible ways to get labeled data as shown in Figure 16. Traditional Supervision: hand label data; Weak supervision: obtained automatically without human annotators using unlabeled data; Semi-supervised learning: partially labeled and partially unlabeled data, and transfer learning: using pre-trained model as a start point.

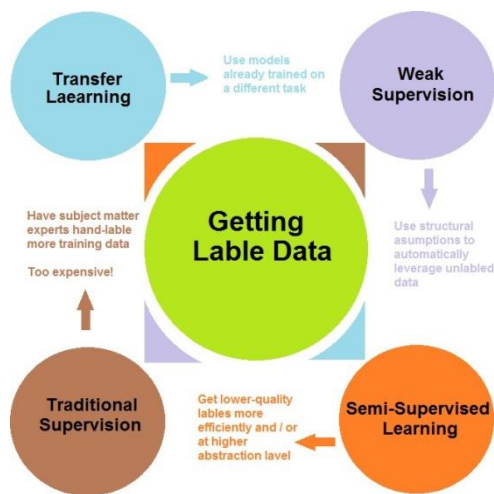

Figure 16: Getting Label Data

Datasets:

The dataset acts as the benchmark against which deep learning networks are trained and tested. Several datasets has been constructed over the last few years that are used in deep learning, motivating researchers to create new models and strategies with better generalization abilities.

These datasets can be categorized according to the nature of data.

The automotive datasets includes; CamVid dataset [180] which is considered as the first with semantically annotated videos, Daimler Urban Segmentation [181], CityScapes [182], Mapillary Vistas [183] and the most recent Apolloscape-Scene



Figure 15: Illustration of the ten categories into which we have classified the reviewed semantic segmentation methods

Table 11: Alternative to CRF based Methods

Category	Strategy / Structure	Corpus	Original Architecture	Testing Benchmark	Published on	Code Available
Alternative to CRF Approaches	Bilateral Neural Network (BNN)[171]	Bilateral filter inference in DenseCRF Replacing Gaussian potentials with bilateral convolution to learn pairwise potentials .	DeepLab	Pascal VOC	June 26, 2016	Yes
	Fast Bilateral Solver (BS) [172]	Edge-aware smoothness algorithm using bilateral filtering technique.	CRF-RNN	Pascal VOC MS COCO	July 22, 2016	-
	Boundary Neural Field (BNF) [173]	Build unary and pairwise potentials from input RGB image, then combine them in global manner.	FCN	Semantic Boundaries Dataset	May 24, 2016	-
	DT-EdgeNet [174]	Domain transform (DT) Module: Edge-preserving filter. Edge Net: Predicts edge features from midway layers.	DeepLab	Pascal VOC	December 12, 2016	-
	Global Convolutional Network (GCN) [175]	Large kernels used for classification and localization. Boundary Refinement Block: Model the boundary alignment as a residual structure.	FCN ResNet	Cityscapes COCO PASCAL VOC	March 8, 2017	-
	Random Walk Network (RWN) [176]	Random Walk Network Pixel labeling framework	DeepLab-largeFOV	Pascal, SBD-Stanford Background, Sift Flow	July 22, 2017	-

parsing [184] which focuses on semantic understanding of urban street scenes. The KITTI [185] dataset used in various computer vision tasks such as 2D/3D object detection, stereo, optical flow, and tracking. Synthetic datasets [186] [187] consist of a thousand images extracted from realistic open-world games.

Data sets generic in nature; PASCAL VOC [188] is one of the most popular and widely used dataset in deep learning semantic segmentation, CIFAR-10/100 [189] contains up to 60,000 images, offering 10 and 100 categories of tiny 32×32 images. A remarkable ImageNet [190] dataset contains over 14 million labeled images, SegTrack v2 [191] is a video segmentation dataset with annotations on multiple objects at each frame, and PASCAL Context [192] is a set of additional annotations for PASCAL VOC. Microsoft-COCO [193] is a collection of images of complex everyday scenes contains common natural objects, ADE20K [194] containing both indoor and outdoor images with large variations, and DAVIS [195] dataset containing densely annotated videos with pixel accurate ground truth. Recently developed COCO stuff [196] dataset augments the original COCO dataset with much more comprehensive stuff annotations.

Indoor environment datasets; NYUDv2 [197] is composed of RGB-D images and video sequences from a variety of indoor scenes, Cornell RGB-D [198] contains labeled office and home scene point clouds, ScanNet [199] comprises more than 1500 scenes annotated with 3D camera pose, surface reconstructions, and semantic segmentations. Stanford 2D-3D [200] contains mutually registered modalities from 2D/3D domains, with 71,882 RGB images (both regular and 360°), along with the corresponding depths, surface normal and semantic annotations. SUN 3D [201] and SUN RGB-D [202] datasets contain videos of big spaces for place-centric scene understanding.

Object datasets; RGB-D Object v2 [203] containing 25000 images of common household objects in 51 categories, YouTube Dataset [204] comprises 126 videos.

Datasets for outdoor environment; Microsoft Cambridge [205] consists of 591 real outdoor scene photographs of 21 object classes; Graz-02 [206] is a natural-scene object category dataset created at INRIA. LabelMe [207] contains outdoor images of 8 different classes that are taken in different cities of Spain; Barcelona dataset [208] is a subset of LabelMe; Stanford-background [209] and PASCAL SBD [210] are collected from PASCAL VOC; Sift-flow [211] consists of 2688 images of 256 × 256 pixels and 33 classes, and Freiburg Forest [212] constitute on outdoor forest environment in different condition lighting, shadows and sun angles.

The dataset construction is both time consuming and labor intensive, so for the researchers and developers the most practical and workable approach is to use existing standard datasets which are representative enough for the domain of the problem. Some datasets have become standard and commonly used by researchers to compare their work with others using standard metric for evaluation. Dataset selection at a start of research is challenging task, therefore the comprehensive description on dataset can help. In **Table 12**, we list the datasets used by deep learning networks that are publicly available. Are given different information such as environment nature, the number of classes, training/testing samples, image resolution, year of construction, and best performances achieved till date (to the best of our knowledge) by the models for semantic segmentation. [13, 198, 203] datasets are not accessed for semantics, but they can be used for semantic segmentation. [184, 199] datasets are not evaluated at all. All these datasets provide appropriate pixel-wise or point-wise labels.

Evaluation:

We describe commonly used evaluation metrics for semantic segmentation. The overall performance of the semantic segmentation systems can be assessed in terms of accuracy, time,

Table 12: Summary of Datasets

DataSet	Environment Nature	No of Classes	Samples			Image Resolution	Year	Performance	Network Model	
			Training	Validation	Test					
ADE20K [194]]	Generic	150	20210	2000	-	Variable	2016	44.98% MIoU	PSPNet [112]	
Apolloscape Scene parsing [184]	Street View / 2D-3D	25	146997 Frames			3384 × 2710	2018			
Barcelona [208]	Outdoor	170	14871	-	279	640 × 480	2010	74.6% GL acc.	DAG-RNN [69]	
CamVid [180]	Street View	32	701			960 × 720	2009	69.94% MIoU	FCCN [83]	
CIFAR-10/100 [189]	Generic / Objects	10/100	50K/500	-	10K/100	32 × 32	2009	3.58% test error	ResNeXt [41]	
Cityscapes [200]	Fine	30	2975	500	1525	2048 × 1024	2016	79.3% MIoU	DeepLabV3 [100]	
	Coarse		22973	500	-			82.2% MIoU	DeepLabV3+ [101]	
Cornell RGB-D [198]	Indoor Office/Home	-	24 Office / 28 Home Scenes Point Clouds			Variable	2011			
COCO Stuff [196]	Generic	172	163957			Variable	2018	38.9% MIoU	DSSPN [43]	
DAVIS [195]	Generic / Videos	4	4219	2023	2180	480p	2017	69.84% MIoU	RFCNet [149]	
Data from Game [187]	Synthetic / Street View	19	24966			1914 × 1052	2016			
Daimler Urban Segmentation [181]	Street View / Video	5	500			1024 × 440	2013	77.2% MIoU	Layered Interpretation [213]	
Freiburg Forest [212]	Outdoor / Forest-Environment	6	230	-	136	1024 × 768	2016	88.25% MIoU	AdapNet [40]	
ImageNet [190]	Generic	1 K	14,197,122			Variable	2010			
INRIA-Graz-02 [206]	Outdoor /Natural	3	479	-	479	640 × 480	2007			
KITTI [185]	Street View	10	140	-	112	1226 × 370	2015	63.51% MIoU	LSDN [214]	
LabelMe [207]	Outdoor	8	2920	-	1133	Variable	2008			
Mapillary Vistas [183]	Street View	66	18000	2000	5000	1920 × 1080	2017	45.01% MIoU	DSSPN [43]	
Microsoft COCO [193]	Generic	80	82783	40504	81434	Variable	2014	56.9% AP	FPN [57]	
Microsoft Cambridge [13]	Outdoor	21	591			320 × 240	2005			
NYUDv2 [197]	Indoor	40	795	654	-	480 × 640	2012	50.1% MIoU	RDFNet [89]	
PASCAL	VOC [188]	Generic	20	1464	-	1449	Variable	2012	89.0% MIoU	DeepLabV3+ [101]
	Context [192]	Generic	59	10103	-	9637	Variable	2014	51.6% MIoU	CCL [115]
		SBD [210]	Outdoor	21	8498	-	2857	Variable	2011	82.1% MIoU
RGB-D Object v2 [203]	Household / Warehouse Objects	51	41877			640 × 480	2014			
ScanNetv2 [199]	Indoor / 3D	20	+1500 scans			Variable	2018			
SegTrack v2 [191]	Generic / Videos	14	976 Frames			Variable	2013	80.12% MIoU	RFCNet [149]	
Sift-Flow [211]	Outdoor	33	2488	-	200	256 × 256	2011	44.9% MIoU	Context-cNN[169]	
Stanford	Background [209]	Outdoor	715			320 × 240	2009	65.7% MIoU	MCRNN [66]	
	2D-3D [200]	Indoor / 2D-3D	13	70469 / 360 Scans			1080 × 1080	2017	49.9% fwIoU	Depth-CNN [215]
SUN Dataset	3D [201]	Indoor / 3D / Video	- 19640 Frames			640 × 80	2013	58.5% IoU	LSTM-CF [216]	
	RGB-D [131]	Indoor / 2D-3D	37	2666	2619	5050	Variable	2015	48.1% MIoU	CCL [115]
SYNTHIA [186]	Synthetic / Street View	11	13407			960 × 720	2016	81.2% MIoU	RFCNet [149]	
Youtube Dataset [204]	Objects / Video	10	+10000 Frames / 126 Videos			480 × 360	2014	68.5% MIoU	Clockwork-FCN [144]	

memory, and power consumption.

Accuracy:

The accuracy of the semantic segmentation system is measure of the correctness of the segmentation or is the ratio of the correctly segmented area over the ground truth.

Pixel wise Accuracy: The ratio between the amount of correctly classified pixels and the total number of them. Confusion matrix terminology is used to describe the performance of a classification model.

Let N_{cls} be the number of classes, N_{xy} is the number of pixels which belong to class x and were labeled as class y . The confusion matrix reports the number of false positives (N_{xy}), false negatives (N_{yx}), true positives (N_{xx}), and true negatives (N_{yy}).

$$PixelAccuracy = \frac{\sum_{x=1}^{N_{cls}} N_{xx}}{\sum_{x=1}^{N_{cls}} \sum_{y=1}^{N_{cls}} N_{xy}} \quad (1)$$

The pixel-wise classification accuracy is not reliable for the real performance of a classifier, because it will yield misleading results if the data set is unbalanced (i.e., large regions which have one class or labeled images could have a more coarse labeling).

Mean Accuracy: The ratio of correct pixels is calculated in per-class basis and then averaged over the total number of classes N_{cls} .

$$MeanAccuracy = \frac{1}{N_{cls}} \sum_{x=1}^{N_{cls}} \frac{N_{xx}}{\sum_{y=1}^{N_{cls}} N_{xy}} \quad (2)$$

Mean Intersection over Union (MIoU): The ratio between the numbers of true positives N_{xx} , (intersection) over the sum of true positives N_{xx} , false negatives N_{yx} , false positives N_{xy} (union). Intersection over Union is computed on a per-class basis and then averaged.

$$MIoU = \frac{1}{N_{cls}} \sum_{x=1}^{N_{cls}} \frac{N_{xx}}{\sum_{y=1}^{N_{cls}} N_{xy} + \sum_{y=1}^{N_{cls}} N_{yx} - N_{xx}} \quad (3)$$

The most widely used accuracy measuring strategy is MIoU, due to its easiness and simplicity.

Frequency Weighted Intersection over Union (FWIoU)

$$FWIoU = \frac{1}{\sum_{x=1}^{N_{cls}} \sum_{y=1}^{N_{cls}} N_{yx}} \sum_{x=1}^{N_{cls}} \frac{\sum_{y=1}^{N_{cls}} N_{xy} N_{xx}}{\sum_{y=1}^{N_{cls}} N_{xy} + \sum_{y=1}^{N_{cls}} N_{yx} - N_{xx}} \quad (4)$$

Precision: The relation between true positives N_{xx} , and all elements classified as positives

$$Precision = \frac{N_{xx}}{N_{xx} + N_{xy}} \quad (5)$$

Recall: measures how good all the positives are found.

$$Recall = \frac{N_{xx}}{N_{xx} + N_{yx}} \quad (6)$$

Average Precision: Mean precision at a set of eleven equal space recall levels (0.0, 0.1, 0.2 . . . , 1)

Mean Average Precision: Mean of all the Average Precision values across all classes.

Time, Memory and Power:

The memory and processing time of the system is highly dependent on hardware and the back-end implementation. The usage of hardware accelerators GPUs makes the processing time of these system very fast, however it consumes much of the memory and power. Most of the methods do not provide information, regarding time, memory and hardware, which is very crucial as these network models may be applied in (mobile systems, robotics, autonomous driving etc) where with limited power and memory, extremely accurate image segmentation would be required. Furthermore, these information can help researchers to estimate, make comparisons or choose methods depending on the application and requirement.

4. ANALYSIS & DISCUSSION

We analyze some of the network models on the bases of their performance on datasets and their design structure to find out the reasons for their accomplishments. It is difficult to compare these methods due to the majority of them has been evaluated on very few datasets. Some methods used different metrics and also lack information about experimental setup (hardware, time, memory).

AdapNet [191]:

- Achieves top score of 88.25% IoU on Freiburg Forest and 72.91% IoU on Synthia dataset. The network achieves the score of 69.39% IoU on cityscapes dataset.

The improvement can be credited to the highly representational multi-scale features learned by the model, which enable the segmentation of very distant objects present in Synthia and Cityscapes. AdapNet model approach is based on a mixture of convolutional neural network (CNN) experts (Convolved Mixture of Deep Experts - CMoDE) and incorporates multiple modalities including appearance, depth and motion.

PSPNet [112]:

- Achieves the best results on ADE20K with 44.8% IoU, promising results are obtained on cityscapes and Pascal VOC with 80.2% IoU and 85.4% IoU respectively.

PSPNet developed an effective optimization strategy for deep ResNet-101 [34] based on deeply supervised loss; two loss functions: main softmax loss to train the final classifier and auxiliary loss applied after the fourth stage, this helps optimizing the learning process. PSPNet applies multi scale testing, experiments different depths of pre-trained ResNet and data augmentation is performed.

FCCN [83]:

- Achieves a top scores of 69.94% IoU on CamVid and score of 44.23% IoU on ADE20K dataset.

FCCN proposed a cost function that significantly improves the segmentation performance, very few researchers tried to modify cost function when training their models. FCCN calculates cost function on each pre output layer including the final output layer.

DeepLab V3 [100]:

- Achieves score of 81.3% IoU on cityscapes.

Improvement mainly comes from changing hyper perimeter: Fine tuning batch normalization, varying batch size, larger crop size, changing output stride, multi scale inputs during inference, add-ing left-right flipped inputs, trained on 3475 finely and extra 20000 coarsely annotated images of cityscapes dataset. Furthermore, the use of ResNet-101 model which is pre-trained on ImageNet and JFT dataset, results in the second best score of 86.90 IoU on Pascal VOC.

DeepLab V3+ [101]:

- Achieves 89.0% IoU on Pascal VOC and 82.1% IoU on cityscapes.

DeepLab V3+ is a modified version of DeepLab V3, adapted to output stride = 16 or 8 instead of 32. It is also adapted to Xception module, which further increased the performance.

DSSPN [43]:

- Achieves top scores on COCO Stuff 38.9% IoU, 43.6% IoU on ADE20K, 58.6% IoU on Pascal Context and 45.01% IoU on Mapillary dataset.

DSSPN constructs a semantic neuron graph in which each neuron segments regions of one parent concept in a semantic concept hierarchy (combining labels from four datasets) and aims at recognizing between its child concepts. Instead of using a completely large semantic neural graph, DSSPN only activates relative small neural graph for each image during training, which makes DSSPN memory and computation efficient.

RFCNet [149]:

- Achieves top scores of 81.20% IoU on SYNTHIA, 80.12% IoU on SegTrack and 69.84% IoU on DAVIS dataset.

The model uses different FCN architectures as a recurrent node to utilize temporal information, deconvolution layer for upsampling and supports skip architecture for finer segmentation. The use of temporal data is the reason for the boost of performance not just simply adding extra convolutional filters.

Adelaide Context CNN-CRF [169]:

- Achieves score of 40.6% IoU on NYUDv2, 42.30% IoU on SUN-RGB, 78.00% IoU on Pascal VOC, 66.40% IoU on CIFAR-100, 71.60% IoU on Cityscapes, and 43.30% IoU on Pascal Context dataset.

The model uses CNN-based pairwise potential functions to capture semantic correlations between neighboring patches which improve the coarse-level prediction. The model applies FCN with sliding pyramid pooling, CNN contextual pairwise, boundary refinement (dense CRF method), and trained model with extra images from the COCO dataset to improve the overall performance of the model.

Clockwork-FCN [144]:

- Achieves 68.50% IoU on Youtube Object, 68.40% IoU on Cityscapes, 28.90% IoU on NYUDv2 dataset.

The Clockwork-FCN uses different clock schedules; Fixed-rate clock reduces computation by assigning different rates to each stage such that later stages execute less often. Adaptive clockwork updates when the output score maps is predicted to change, thus reducing computation while maintaining accuracy.

Residual framework ResNet-38 [38]:

- Achieves the highest score of 48.1% IoU on Pascal Context, 80.6% IoU on cityscapes and 43.43% IoU on ADE20K.

The model introduces residual units into ResNet (17 residual units for 101 layers ResNet) expanding it into a sufficiently large number of sub-networks. Each connection in residual unit shares same kernel sizes and numbers of channels, this results in improving model accuracy. ResNet-38 does not apply any multi-scale testing, model averaging or CRF based post-processing, except for the test set of ADE20K.

ESPNet: [47]:

- Efficient real-time segmentation network, achieves 60.2% IoU on cityscape, 40.0% IoU on Mapillary dataset with 0.364M parameters, 63.01% IoU on Pascal VOC test set with 0.364M parameters.

Efficient Spatial Pyramid (ESP) network is an efficient neural network in terms of speed and memory. ESP, based on factorized form of convolutions (point-wise convolution and spatial pyramid of dilated convolutions), reduces the number of parameters, memory, with large receptive field.

FCN-8s [77]:

- Achieves the score of 77.46% IoU on Freiburg Forest, 67.20% IoU on PASCAL VOC, 65.30% IoU on CIFAR-10, 65.30% IoU on Cityscapes, 56.10% IoU on KITTI, 29.39% IoU on ADE20K, 35.10% IoU on PASCAL CONTEXT, 65.24% IoU on SYNTHIA, and 57.00% IoU on CamVid dataset.

The performance is increased by transferring pre-trained classifier weights, fusing different layer representations, and learning end-to-end on whole images.

DAG-RNN [72]:

- Achieves 44.8% IoU on Sift-flow, 31.2% IoU on COCO stuff (171 classes) and 43.7% IoU on PASCAL Context dataset.

Segmentation network uses a pre-trained CNN with DAG-RNN, fusing low-level features with DAG-RNN. A new class weighted loss function proposed to control the classwise loss during training. The performance of segmentation network increases with increase in DAGs with DAG-RNN. Fully connected CRF is used, which further improves the performance of the network.

RefineNet [88]:

- Achieves a score of 45.90% IoU on SUN-RGB, 46.50% IoU on NYUDv2 and 47.30% IoU on Pascal Context datasets. The results on Pascal VOC, cityscapes, and ADE20K datasets are 83.40% IoU, 73.60% IoU, and 40.70 % IoU respectively.

RefineNet applies data augmentation during training (random scaling, cropping and horizontal flipping of image), and multi-scale evaluation (average the predictions on the same image across different scales for the final prediction). Dense CRF method is used only for Pascal VOC.

Dilation10 [98]:

- Achieves 67.60% IoU on PASCAL VOC, 67.10% IoU on Cityscapes, 32.31% IoU on ADE20K and 65.29% IoU on CamVid dataset.

The model is an adapted version of [69], replacing the pooling and convolutional layers of conv4/conv5 with two dilated convolution layers with dilation factors of 2 and 4 respectively. This leads to a decrease in the size of the network and its running time for real-time applications.

ResNet DUC+HDC [103]:

- Achieves a score of 80.10% IoU on Cityscapes, 83.10% IoU on PASCAL VOC, 39.40% IoU on ADE20K dataset.

DUC provides the dense pixel-wise predictions, HDC uses arbitrary dilation rates which enlarge the receptive fields of the network. ResNet with different depths are experimented, data augmentation is performed (for cityscapes, each image of the training set is partitioned into twelve 800× 800 patches making 35700 images). The model is trained using the combination of MS-COCO dataset, augmented PASCAL VOC 2012 training and trainval sets. ResNet DUC+HDC is also evaluated on KITTI dataset achieving the average precision of 92.88% for road segmentation using ResNet 101-DUC model, pre-trained from ImageNet during training.

ST-Dilation [145]:

- Achieves the score of 65.90% IoU on CamVid dataset. Model ST-FCN32s scores 50.60% IoU on Camvid dataset and Model ST-FCN8s scores 30.90% IoU on NYUDv2 dataset.

In STFCN model, no post processing required, the spatial temporal module is embedded on top of the final convolutional layer. LSTM blocks are used for inferring the relations between spatial features that provide valuable information and improve the accuracy of the segmentation. Furthermore, applying dilated convolutions for multi-scale contextual information archives better results.

STGRU (GRFP + Dilation) [151]:

- Achieves the score of 66.10 IoU on CamVid dataset. Model GRFP + Dilation scores 67.80% IoU and model GRFP + LRR-4x achieves the score of 72.80% IoU on Cityscapes dataset.

The model combines the power of both convolutional-gated architecture and spatial transformers (CNN). The model GRFP is trained with Dilation 10 [88] and LRR [70] network that improve performance for video. The model improves semantic video segmentation and labeling accuracy by propagating information from labeled video frames to nearby unlabeled frames with slight computation.

It can be noticed, that those methods which achieved the high performance results, are doing so due to the availability of large amount of labeled data. Extra training data is beneficial for increasing the accuracy of the model; several models used large datasets (merging two or three datasets) during training.

5. OPEN PROBLEMS AND CHALLENGES

In this section, we discuss some of the open problems and their possible solutions.

Open Problems and Possible Solutions

Techniques for semantic segmentation using deep neural networks (DNNs) are rapidly growing and the following problems are still needed to be addressed.

1. Reducing Complexity & Computation:

The deep neural networks are not much suitable to be deployed on mobile platforms (e.g. embedded devices) that have limited resources because, DNN are highly memory demanding, time and power consuming. There is also problem with computational complexity that arises due to a great number of operations needed for inference. It is important to investigate how to reduce the complexity of the model to achieve high efficiency without loss of accuracy. Some CNN compression approaches have been proposed to deal with reducing complexity and computational cost. Wang et al. [217] proposed a method to excavate and decrease the redundancy in feature maps extracted from large number of filters in each layer of network. Kim et al. [218] proposed a one-shot whole network compression approach, that consists of three steps: Rank selection, Low-rank tensor decomposition, and fine tuning. Andrew et al. [219] applied model compression techniques to the problem of semantic segmentation.

Caffe2 is a portable deep learning framework by Facebook, capable of training large models and allows to build machine learning applications for mobile systems. Compressing and accelerating DNN achieved lots of progress. However, there are some potential issues like; compression may cause loss in accuracy; decomposition operation; transfer information to convolutional filters is not suitable on some networks.

2. Apply to Adverse Conditions:

There have been a few of network models which are applied in real challenging environmental conditions or to handle adverse conditions such as direct lighting, reflections from specular surfaces, varying seasons, fog or rain. Although, some CNN models used synthetic data together with real data to boost the performance of state-of-the-art methods for semantic segmentation on the challenging environmental conditions. However, using huge amounts of high-quality data from the real world so far remains indispensable. One possible solution is to use synthetic data with the real data. Apparently there are significant visual differences between the two data domains and to narrow this gap, domain adaptation technique may be used. Hoffman et al. [220] proposed an unsupervised domain adaptation method for transferring semantic segmentation FCNs across image domains. Yang et al. [221] proposed a curriculum-style learning approach to minimize the domain gap. The authors in [222] proposed a domain Shift approach based on Generative Adversarial Network (GAN), which transfers the information of the target distribution to the learned embedding using a generator-discriminator pair.

3. Need large and high quality labeled data:

The classification performance of DNNs and dataset size are positively correlated. Current state-of-the-art methods require high quality labeled data, which is not available on large-scale as they are time consuming and labour exhaustive. The effective solution to this problem would be to build large and high quality datasets, which seems hard to achieve. Therefore, the researchers rely on semi and weakly supervised methods making DNNs less reliant on the labeling of large datasets. These methods has considerably improved the semantic segmentation performance by using additional weak annotations either alone or in combination with a small number of strong annotations. However, they are far from fully supervised learning methods in terms of accuracy. Thus, this opens new challenges for improvement.

4. Overfitting:

As mentioned before, DNNs are data hungry and they do not perform well unless they are fed with large datasets. Majority of the available datasets are relatively small, so as DNN models become very complex to capture all the useful information necessary to solve a problem. The model may run risk of "Overfitting" with limited amount

of data. Overfitting occurs when the gap between the training error and test error is too large. Regularization techniques help in overcoming this problem. Regularization is any modification we make to a learning algorithm that is intended to reduce its generalization error but not its training error [60]. Several of these methods are applied in DNNs to prevent overfitting such as L1 and L2 regularization, Lp norm, dropout, dropConnect. Data Augmentation is also used to reduce overfitting (e.g. increasing the size of the training data - image rotating, flipping, scaling, shifting). However, the regularization may increase training time (e.g. using dropout increases the training time by 2x or 3x than a standard neural network of the same architecture) and there is no standard for regularizing CNNs. Introducing better or improved regularization method would be an interesting direction for future work.

5. Segmentation in Real-time:

Real-time semantic segmentation without loosing to much accuracy is of great importance, as it can be useful in autonomous driving, robot interaction, mobile computing where running time is critical to evaluate the performance of the system. DNN methods for semantic segmentation are more focused on accuracy then speed. Majority of the methods are far away from real-time segmentation. One possible solution to the problem could be performing convolutions in an efficient manner. Several works have aimed at developing efficient architectures that can run in real-time based on convolution factorization (disintegrate convolutional operation into multiple steps). Some computationally efficient modules for convolution are introduced. For example, Inception [27], Xception [31], ResNet [34], ASP [99], ESP [47]; ShuffleNet [223] and MobileNet [224], are using grouped and depth-wise convolutions. Another possible solution could be to apply network compression using different techniques (e.g. parameter pruning and sharing [225], low-rank factorization and sparsity [226] etc) to reduce the size of the network. However, real-time semantic segmentation still lacks higher accuracy and new methods and approaches must be developed to work-out between runtime and accuracy.

6. Video / 3D Segmentation:

DNNs have been successfully applied for semantic segmentation of 2D images while not much for 3D images and on videos despite their significance. Several video and 3D network models for semantic segmentation have been proposed over the years and progress has been made but some challenges still exist. The lack of large datasets of 3D images and sequence images (videos) make it difficult to progress on 3D and video semantic segmentation. 3D networks are computationally expensive when dealing with high resolution and complex scenes (large number of classes). In 3D semantic segmentation task, using 3D Point cloud information is very effective. Zhang et al.

[227] proposed an efficient large-scale point cloud segmentation method, in which 2D images with 3D point clouds are fused into CNN to segment complex 3D urban scenes. The authors in [228, 229] proposed methods for direct semantic labeling of 3D pointclouds with spectral information. However, 3D segmentation methods face many challenges as compared to 2D segmentation, i.e., High complexity, computational cost, slow processing and most important lack of 3D datasets. In video semantic segmentation, two approaches can be useful, one to improve computational cost (by reducing latency); The authors in [144, 230] proposed designed schedule frameworks which reduce the overall cost and maximum latency of video semantic segmentation. However, these approaches are far away to meet the latency requirements in real-time applications. The second approach is to improve accuracy (by exploiting temporal continuity - temporal features and temporal correlations between video frames). Several methods [145, 146, 148] have been proposed using temporal information with spatial information for increasing the accuracy of pixel labeling.

6. CONCLUSIONS

In this paper, we have provided a comprehensive survey of deep learning techniques used for semantic segmentation.

The surveyed methods have been categorized in ten classes, according to the common concept underlying their architectures. We have also provided a summary of these methods stating, for each of them, the main idea, the origin of its architecture, testing benchmarks, code availability and the year of publication.

Thirty five datasets on which these methods have been applied, have been reported and described in details showing their environment nature, number of classes, resolution, number of the images and the method which achieved the best performance on each till date to the best of our knowledge.

We have mainly analyzed the design and performance of some of these methods which reported that had achieved high scores. The goal was to find out how they do so.

We have also discussed some of the open problems and tried to suggest some of possible solutions.

This survey had shown that there is much scope of improvement in terms of accuracy, speed and complexity. So, our future work, would be to take some of these methods and develop a new one by enhancement of the weaknesses and/or combination of the merits.

ACKNOWLEDGMENT

The authors express their gratitude to University Technology Belfort-Montbeliard and Higher Education Commission of Pakistan for providing the support and necessary requirement for completion of work. The authors would also like to acknowledge Zhi Yan and Abdellatif El Idrissi for helpful discussions.

APPENDIX: Table .13

REFERENCES

- [1] D. D. Cox, T. Dean, Neural networks and neuroscience-inspired computer vision, *Current Biology* 24 (18) (2014) R921–R929.
- [2] B. Li, S. Liu, W. Xu, W. Qiu, Real-time object detection and semantic segmentation for autonomous driving, in: *MIPPR 2017: Automatic Target Recognition and Navigation*, Vol. 10608, International Society for Optics and Photonics, 2018, p. 106080P.
- [3] Y.-H. Tseng, S.-S. Jan, Combination of computer vision detection and segmentation for autonomous driving, in: *Position, Location and Navigation Symposium (PLANS)*, 2018 IEEE/ION, IEEE, 2018, pp. 1047–1052.
- [4] Y. Zhang, H. Chen, Y. He, M. Ye, X. Cai, D. Zhang, Road segmentation for all-day outdoor robot navigation, *Neurocomputing* 314 (2018) 316–325.
- [5] X. Tao, D. Zhang, W. Ma, X. Liu, D. Xu, Automatic metallic surface defect detection and recognition with convolutional neural networks, *Applied Sciences* 8 (9) (2018) 1575.
- [6] R. Kemker, C. Salvaggio, C. Kanan, Algorithms for semantic segmentation of multispectral remote sensing imagery using deep learning, *ISPRS Journal of Photogrammetry and Remote Sensing*.
- [7] Y. Ji, H. Zhang, K.-K. Tseng, T. W. Chow, Q. J. Wu, Graph model-based salient object detection using objectness and multiple saliency cues, *Neurocomputing* 323 (2019) 188–202.
- [8] Y. Ji, H. Zhang, Q. J. Wu, Salient object detection via multi-scale attention cnn, *Neurocomputing* 322 (2018) 130–140.
- [9] A. Milioto, P. Lottes, C. Stachniss, Real-time semantic segmentation of crop and weed for precision agriculture robots leveraging background knowledge in cnns, in: *2018 IEEE International Conference on Robotics and Automation (ICRA)*, IEEE, 2018, pp. 2229–2235.
- [10] H. Zhang, Y. Sun, L. Liu, X. Wang, L. Li, W. Liu, Clothingout: a category-supervised gan model for clothing segmentation and retrieval, *Neural Computing and Applications* (2018) 1–12.
- [11] F. Jiang, A. Grigorev, S. Rho, Z. Tian, Y. Fu, W. Jifara, K. Adil, S. Liu, Medical image semantic segmentation based on deep learning, *Neural Computing and Applications* 29 (5) (2018) 1257–1265.
- [12] J. Shotton, M. Johnson, R. Cipolla, Semantic texton forests for image categorization and segmentation, in: *Computer vision and pattern recognition, 2008, IEEE*, 2008, pp. 1–8.
- [13] J. Shotton, A. Fitzgibbon, M. Cook, T. Sharp, M. Finocchio, R. Moore, A. Kipman, A. Blake, Real-time human pose recognition in parts from single depth images, in: *Computer Vision and Pattern Recognition (CVPR)*, 2011 IEEE Conference on, IEEE, 2011, pp. 1297–1304.
- [14] Semantic segmentation deep learning review, www.blog.qure.ai.
- [15] H. Zhu, F. Meng, J. Cai, S. Lu, Beyond pixels: A comprehensive survey from bottom-up to semantic image segmentation and cosegmentation, *Journal of Visual Communication and Image Representation* 34 (2016) 12–27.
- [16] M. Thoma, A survey of semantic segmentation, *arXiv preprint arXiv:1602.06541*.
- [17] J. Niemeijer, P. P. Fouopi, S. Knake-Langhorst, E. Barth, A review of neural network based semantic segmentation for scene understanding in context of the self driving car, *BioMedTec Studierendentagung*.
- [18] Y. Guo, Y. Liu, T. Georgiou, M. S. Lew, A review of semantic segmentation using deep neural networks, *International Journal of Multimedia Information Retrieval* 7 (2) (2018) 87–93.
- [19] Q. Geng, Z. Zhou, X. Cao, Survey of recent progress in semantic image segmentation with cnns, *Science China Information Sciences* 61 (5) (2018) 051101.
- [20] A. Garcia-Garcia, S. Orts-Escolano, S. Oprea, V. Villena-Martinez, J. Garcia-Rodriguez, A review on deep learning techniques applied to semantic segmentation, *Soft Computing* 70 (2017) 41–65.
- [21] H. Yu, Z. Yang, L. Tan, Y. Wang, W. Sun, M. Sun, Y. Tang, Methods and datasets on semantic segmentation: A review, *Neurocomputing* 304 (2018) 82–103.
- [22] Y. LeCun, L. Bottou, Y. Bengio, P. Haffner, Gradient-based learning applied to document recognition, *Proceedings of the IEEE* 86 (11) (1998) 2278–2324.

Table .13: Links to the Source Codes

Network Model	Code Link	Network Model	Code Link
Inception[27]		RSIS [75]	https://github.com/imatge-upc/rsis
BN-Inception [28]	https://github.com/Microsoft/CNTK/tree/master/examples/Image/Classification/GoogLeNet	FC-DenseNet [51]	https://github.com/SimJeg/FC-DenseNet
Inception V2, V3 [29]		ConvDeconvNet [79]	https://github.com/HyeonwooNoh/DeconvNet
Inception V4 [30]	https://github.com/titu1994/Inception-v4	SegNet [80]	https://github.com/alexgkendall/caffe-segnet
Xception [31]	https://github.com/kwotsin/TensorFlow-Xception	FCN [77]	https://github.com/shelhamer/fcn.berkeleyvision.org
VGGNet [33]	https://github.com/machrisaa/tensorflow-vgg	SMSNet [84]	https://github.com/JohanVer/SMSNet
ResNet [34]	https://github.com/KaimingHe/deep-residual-networks	ICNet [87]	https://github.com/hszha0/ICNet
ResNet-38 [38]	https://github.com/itijyou/ademxapp	RefineNet [88]	https://github.com/guosheng/refinenet
ResNeXt [41]	https://github.com/facebookresearch/ResNeXt	RDFNET [89]	https://github.com/SeongjinPark/RDFNet/blob/master
INPLACE-ABN [42]	https://github.com/mapillary/inplace_abn	G-FRNet [90]	https://github.com/mrochan/gfrnet
FRRN [44]	https://github.com/TobyPDE/FRRN	LRN [91]	https://github.com/golnazghiasi/LRN
ENet [45]	https://github.com/TimoSaemann/ENet	DeepLab [97]	https://bitbucket.org/deeplab/deeplab-public
ERFNet [46]	https://github.com/Eromera/erfnet	DeepLabV2 [99]	https://bitbucket.org/aquariusjay/deeplab-public-ver2
ESPNet [47]	https://github.com/sacmehta/ESPNet	Dilation [98]	https://github.com/tensorflow/models/tree/master/research/deeplab
R-CNN [52]	https://github.com/rbgirshick/rcnn	DeepLabV3+ [101]	https://github.com/fyu/dilation
Fast R-CNN [54]	https://github.com/rbgirshick/fast-rcnn	HDC [103]	https://github.com/TuSimple/TuSimple-DUC
Faster R-CNN [55]	https://github.com/ShaoqingRen/faster_rcnn	DRN [104]	https://github.com/fyu/drn
Mask R-CNN [56]	https://github.com/matterport/Mask-RCNN	PSPNet [112]	https://github.com/hszha0/PSPNet
FPN [57]	https://github.com/unsqy/FPN	DenseCRF [160]	https://github.com/lucasb-eyer/pydensecrf
DecoupledNet [122]	https://github.com/HyeonwooNoh/DecoupledNet	GCF [163]	https://github.com/siddharthachandra/gcrf
WSSL [123]	https://bitbucket.org/deeplab/deeplab-public	ConvCRF [164]	https://github.com/MarvinTeichmann/ConvCRF
Semi-Adv [127]	https://github.com/hfslyc/AdvSemiSeg	BNN [171]	https://github.com/MPI-IS/bilateralINN
DSRG [132]	https://github.com/speedinghzl/DSRG	Clockwork [144]	https://github.com/shelhamer/clockwork-fcn
MCG GrabCut+ [137]	https://github.com/philferriere/tfsws	STFCN [145]	https://github.com/MohsenFayyaz89/STFCN
ReSeg [64]	https://github.com/fvisin/reseg	FSO [147]	https://bitbucket.org/infinitei/vidoeoparsing

- [23] A. Krizhevsky, I. Sutskever, G. E. Hinton, Imagenet classification with deep convolutional neural networks, in: Advances in neural information processing systems, 2012, pp. 1097–1105.
- [24] M. D. Zeiler, R. Fergus, Visualizing and understanding convolutional networks, in: European conference on computer vision, Springer, 2014, pp. 818–833.
- [25] M. Lin, Q. Chen, S. Yan, Network in network, arXiv preprint arXiv:1312.4400.
- [26] F. Rosenblatt, Principles of neurodynamics. perceptrons and the theory of brain mechanisms, Tech. rep., CORNELL AERONAUTICAL LAB INC BUFFALO NY (1961).
- [27] C. Szegedy, W. Liu, Y. Jia, P. Sermanet, S. Reed, D. Anguelov, D. Erhan, V. Vanhoucke, A. Rabinovich, Going deeper with convolutions, in: Proceedings of the IEEE conference on computer vision and pattern recognition, 2015, pp. 1–9.
- [28] S. Ioffe, C. Szegedy, Batch normalization: Accelerating deep network training by reducing internal covariate shift, arXiv preprint arXiv:1502.03167.
- [29] C. Szegedy, V. Vanhoucke, S. Ioffe, J. Shlens, Z. Wojna, Rethinking the inception architecture for computer vision, in: Proceedings of the IEEE conference on computer vision and pattern recognition, 2016, pp. 2818–2826.
- [30] C. Szegedy, S. Ioffe, V. Vanhoucke, A. A. Alemi, Inception-v4, inception-resnet and the impact of residual connections on learning., in: AAAI, Vol. 4, 2017, p. 12.
- [31] F. Chollet, Xception: Deep learning with depthwise separable convolutions, arXiv preprint (2017) 1610–02357.
- [32] F. Mamalet, C. Garcia, Simplifying convnets for fast learning, in: International Conference on Artificial Neural Networks, Springer, 2012, pp. 58–65.
- [33] K. Simonyan, A. Zisserman, Very deep convolutional networks for large-scale image recognition, arXiv preprint arXiv:1409.1556.
- [34] K. He, X. Zhang, S. Ren, J. Sun, Deep residual learning for image recognition, in: Proceedings of the IEEE conference on computer vision and pattern recognition, 2016, pp. 770–778.
- [35] G. E. Hinton, S. Osindero, Y.-W. Teh, A fast learning algorithm for deep belief nets, Neural computation 18 (7) (2006) 1527–1554.
- [36] G. E. Hinton, Deep belief networks, Scholarpedia 4 (5) (2009) 5947.
- [37] W. Byeon, T. M. Breuel, F. Raue, M. Liwicki, Scene labeling with lstm recurrent neural networks, in: Proceedings of the IEEE Conference on Computer Vision and Pattern Recognition, 2015, pp. 3547–3555.
- [38] Z. Wu, C. Shen, A. v. d. Hengel, Wider or deeper: Revisiting the resnet model for visual recognition, arXiv preprint arXiv:1611.10080.
- [39] A. Casanova, G. Cucurull, M. Drozdal, A. Romero, Y. Bengio, On the iterative refinement of densely connected representation levels for semantic segmentation, arXiv preprint arXiv:1804.11332.
- [40] A. Valada, J. Vertens, A. Dhall, W. Burgard, Adapnet: Adaptive semantic segmentation in adverse environmental conditions, in: Robotics and Automation (ICRA), 2017 IEEE International Conference on, IEEE, 2017, pp. 4644–4651.
- [41] S. Xie, R. Girshick, P. Dollár, Z. Tu, K. He, Aggregated residual transformations for deep neural networks, in: Computer Vision and Pattern Recognition (CVPR), 2017 IEEE Conference on, IEEE, 2017, pp. 5987–5995.
- [42] S. R. Bulò, L. Porzi, P. Kotschieder, In-place activated batchnorm for memory-optimized training of dnns, CoRR, abs/1712.02616, December 5.
- [43] X. Liang, H. Zhou, E. Xing, Dynamic-structured semantic propagation network, in: Proceedings of the IEEE Conference on Computer Vision and Pattern Recognition, 2018, pp. 752–761.
- [44] T. Pohlen, A. Hermans, M. Mathias, B. Leibe, Fullresolution residual networks for semantic segmentation in street scenes, arXiv preprint.
- [45] A. Paszke, A. Chaurasia, S. Kim, E. Culurciello, Enet: A deep neural network architecture for real-time semantic segmentation, arXiv preprint arXiv:1606.02147.
- [46] E. Romera, J. M. Alvarez, L. M. Bergasa, R. Arroyo, Erfnet: Efficient residual factorized convnet for real-time semantic segmentation, IEEE Transactions on Intelligent Transportation Systems 19 (1) (2018) 263–272.
- [47] S. Mehta, M. Rastegari, A. Caspi, L. Shapiro, H. Hajishirzi, Espnet: Efficient spatial pyramid of dilated convolutions for semantic segmentation, arXiv preprint arXiv:1803.06815.
- [48] L. Deng, M. Yang, H. Li, T. Li, B. Hu, C. Wang, Restricted deformable convolution based road scene semantic segmentation using surround view cameras, arXiv preprint arXiv:1801.00708.
- [49] G. Huang, Y. Sun, Z. Liu, D. Sedra, K. Q. Weinberger, Deep networks with stochastic depth, in: European Conference on Computer Vision, Springer, 2016, pp. 646–661.
- [50] A. Veit, M. J. Wilber, S. Belongie, Residual networks behave like ensembles of relatively shallow networks, in: Advances in Neural Information Processing Systems, 2016, pp. 550–558.
- [51] S. Jégou, M. Drozdal, D. Vazquez, A. Romero, Y. Bengio, The one hundred layers tiramisù: Fully convolutional densenets for semantic segmentation, in: Computer Vision and Pattern Recognition Workshops

- (CVPRW), 2017 IEEE Conference on, IEEE, 2017, pp. 1175–1183.
- [52] R. Girshick, J. Donahue, T. Darrell, J. Malik, Rich feature hierarchies for accurate object detection and semantic segmentation, in: Proceedings of the IEEE conference on computer vision and pattern recognition, 2014, pp. 580–587.
- [53] J. R. Uijlings, K. E. Van De Sande, T. Gevers, A. W. Smeulders, Selective search for object recognition, *International journal of computer vision* 104 (2) (2013) 154–171.
- [54] R. Girshick, Fast r-cnn, in: Proceedings of the IEEE international conference on computer vision, 2015, pp. 1440–1448.
- [55] S. Ren, K. He, R. Girshick, J. Sun, Faster r-cnn: Towards real-time object detection with region proposal networks, in: *Advances in neural information processing systems*, 2015, pp. 91–99.
- [56] K. He, G. Gkioxari, P. Dollár, R. Girshick, Mask r-cnn, in: *Computer Vision (ICCV)*, 2017 IEEE International Conference on, IEEE, 2017, pp. 2980–2988.
- [57] T.-Y. Lin, P. Dollár, R. B. Girshick, K. He, B. Hariharan, S. J. Belongie, Feature pyramid networks for object detection., in: *CVPR*, Vol. 1, 2017, p. 4.
- [58] S. Liu, L. Qi, H. Qin, J. Shi, J. Jia, Path aggregation network for instance segmentation, in: *Proceedings of the IEEE Conference on Computer Vision and Pattern Recognition*, 2018, pp. 8759–8768.
- [59] J. Hosang, R. Benenson, P. Dollár, B. Schiele, What makes for effective detection proposals?, *IEEE transactions on pattern analysis and machine intelligence* 38 (4) (2016) 814–830.
- [60] I. Goodfellow, Y. Bengio, A. Courville, *Deep Learning*, MIT Press, 2016, <http://www.deeplearningbook.org>.
- [61] A. Graves, A.-r. Mohamed, G. Hinton, Speech recognition with deep recurrent neural networks, in: *Acoustics, speech and signal processing (icassp)*, 2013 IEEE international conference on, IEEE, 2013, pp. 6645–6649.
- [62] F. Gao, L. Wu, L. Zhao, T. Qin, X. Cheng, T.-Y. Liu, Efficient sequence learning with group recurrent networks, in: *Proceedings of the 2018 Conference of the North American Chapter of the Association for Computational Linguistics: Human Language Technologies, Volume 1 (Long Papers)*, Vol. 1, 2018, pp. 799–808.
- [63] S. Hochreiter, J. Schmidhuber, Long short-term memory, *Neural computation* 9 (8) (1997) 1735–1780.
- [64] F. Visin, M. Ciccone, A. Romero, K. Kastner, K. Cho, Y. Bengio, M. Matteucci, A. Courville, Reseg: A recurrent neural network-based model for semantic segmentation, in: *Proceedings of the IEEE Conference on Computer Vision and Pattern Recognition Workshops*, 2016, pp. 41–48.
- [65] F. Visin, K. Kastner, K. Cho, M. Matteucci, A. Courville, Y. Bengio, Renet: A recurrent neural network based alternative to convolutional networks, *arXiv preprint arXiv:1505.00393*.
- [66] H. Fan, X. Mei, D. Prokhorov, H. Ling, Multi-level contextual rnns with attention model for scene labeling, *IEEE Transactions on Intelligent Transportation Systems* (99) (2018) 1–11.
- [67] L.-C. Chen, Y. Yang, J. Wang, W. Xu, A. L. Yuille, Attention to scale: Scale-aware semantic image segmentation, in: *Proceedings of the IEEE conference on computer vision and pattern recognition*, 2016, pp. 3640–3649.
- [68] P. H. Pinheiro, R. Collobert, Recurrent convolutional neural networks for scene labeling, in: *31st International Conference on Machine Learning (ICML)*, no. EPFL-CONF-199822, 2014.
- [69] B. Shuai, Z. Zuo, B. Wang, G. Wang, Dag-recurrent neural networks for scene labeling, in: *Proceedings of the IEEE conference on computer vision and pattern recognition*, 2016, pp. 3620–3629.
- [70] H. Fan, H. Ling, Dense recurrent neural networks for scene labeling, *arXiv preprint arXiv:1801.06831*.
- [71] G. Huang, Z. Liu, L. Van Der Maaten, K. Q. Weinberger, Densely connected convolutional networks., in: *CVPR*, Vol. 1, 2017, p. 3.
- [72] B. Shuai, Z. Zuo, B. Wang, G. Wang, Scene segmentation with dag-recurrent neural networks, *IEEE transactions on pattern analysis and machine intelligence* 40 (6) (2018) 1480–1493.
- [73] K. Cho, B. Van Merriënboer, C. Gulcehre, D. Bahdanau, F. Bougares, H. Schwenk, Y. Bengio, Learning phrase representations using rnn encoder-decoder for statistical machine translation, *arXiv preprint arXiv:1406.1078*.
- [74] S. Hochreiter, J. Schmidhuber, Long short-term memory, *Neural computation* 9 (8) (1997) 1735–1780.
- [75] A. Salvador, M. Bellver, M. Baradad, F. Marqués, J. Torres, X. Giro-i Nieto, Recurrent neural networks for semantic instance segmentation, *arXiv preprint arXiv:1712.00617*.
- [76] S. Xingjian, Z. Chen, H. Wang, D.-Y. Yeung, W.-K. Wong, W.-c. Woo, Convolutional lstm network: A machine learning approach for precipitation nowcasting, in: *Advances in neural information processing systems*, 2015, pp. 802–810.
- [77] J. Long, E. Shelhamer, T. Darrell, Fully convolutional networks for semantic segmentation, in: *Proceedings of the IEEE conference on computer vision and pattern recognition*, 2015, pp. 3431–3440.
- [78] Y. Wang, J. Liu, Y. Li, J. Yan, H. Lu, Objectness-aware semantic segmentation, in: *Proceedings of the 2016 ACM on Multimedia Conference, ACM*, 2016, pp. 307–311.
- [79] H. Noh, S. Hong, B. Han, Learning deconvolution network for semantic segmentation, in: *Proceedings of the IEEE international conference on computer vision*, 2015, pp. 1520–1528.
- [80] V. Badrinarayanan, A. Kendall, R. Cipolla, Segnet: A deep convolutional encoder-decoder architecture for image segmentation., *CoRR abs/1511.00561*.
- [81] J. Fu, J. Liu, Y. Wang, H. Lu, Stacked deconvolutional network for semantic segmentation, *arXiv preprint arXiv:1708.04943*.
- [82] G. Nanfack, A. Elhassouny, R. O. H. Thami, Squeeze-segnet: a new fast deep convolutional neural network for semantic segmentation, in: *Tenth International Conference on Machine Vision (ICMV 2017)*, Vol. 10696, International Society for Optics and Photonics, 2018, p. 106962O.
- [83] T. Yang, Y. Wu, J. Zhao, L. Guan, Semantic segmentation via highly fused convolutional network with multiple soft cost functions, *Cognitive Systems Research*.
- [84] J. Vertens, A. Valada, W. Burgard, Smsnet: Semantic motion segmentation using deep convolutional neural networks, in: *Intelligent Robots and Systems (IROS)*, 2017 IEEE/RSS International Conference on, IEEE, 2017, pp. 582–589.
- [85] E. Ilg, N. Mayer, T. Saikia, M. Keuper, A. Dosovitskiy, T. Brox, FlowNet 2.0: Evolution of optical flow estimation with deep networks, in: *IEEE conference on computer vision and pattern recognition (CVPR)*, Vol. 2, 2017, p. 6.
- [86] P. Bilinski, V. Prisacariu, Dense decoder shortcut connections for single-pass semantic segmentation, in: *Proceedings of the IEEE Conference on Computer Vision and Pattern Recognition*, 2018, pp. 6596–6605.
- [87] H. Zhao, X. Qi, X. Shen, J. Shi, J. Jia, Icnets for real-time semantic segmentation on high-resolution images, *arXiv preprint arXiv:1704.08545*.
- [88] G. Lin, A. Milan, C. Shen, I. D. Reid, Refinenet: Multi-path refinement networks for high-resolution semantic segmentation., in: *Cvpr*, Vol. 1, 2017, p. 5.
- [89] S. Lee, S.-J. Park, K.-S. Hong, Rdfnet: Rgb-d multi-level residual feature fusion for indoor semantic segmentation, in: *Computer Vision (ICCV)*, 2017 IEEE International Conference on, IEEE, 2017, pp. 4990–4999.
- [90] M. A. Islam, M. Rochan, N. D. Bruce, Y. Wang, Gated feedback refinement network for dense image labeling, in: *2017 IEEE Conference on Computer Vision and Pattern Recognition (CVPR)*, IEEE, 2017, pp. 4877–4885.
- [91] M. A. Islam, S. Naha, M. Rochan, N. Bruce, Y. Wang, Label refinement network for coarse-to-fine semantic segmentation, *arXiv preprint arXiv:1703.00551*.
- [92] G. Ghiasi, C. C. Fowlkes, Laplacian pyramid reconstruction and refinement for semantic segmentation, in: *European Conference on Computer Vision*, Springer, 2016, pp. 519–534.
- [93] F. J. Huang, Y.-L. Boureau, Y. LeCun, et al., Unsupervised learning of invariant feature hierarchies with applications to object recognition, in: *Computer Vision and Pattern Recognition, 2007. CVPR'07. IEEE Conference on*, IEEE, 2007, pp. 1–8.
- [94] P. J. Burt, E. H. Adelson, The laplacian pyramid as a compact image code, in: *Readings in Computer Vision*, Elsevier, 1987, pp. 671–679.
- [95] Y. Wu, T. Yang, J. Zhao, L. Guan, J. Li, Fully combined convolutional network with soft cost function for traffic scene parsing, in: *International Conference on Intelligent Computing*, Springer, 2017, pp. 725–731.
- [96] F. N. Iandola, S. Han, M. W. Moskewicz, K. Ashraf, W. J. Dally, K. Keutzer, Squeezenet: Alexnet-level accuracy with 50x fewer parameters and 0.5 mb model size, *arXiv preprint arXiv:1602.07360*.

- [97] L.-C. Chen, G. Papandreou, I. Kokkinos, K. Murphy, A. L. Yuille, Semantic image segmentation with deep convolutional nets and fully connected crfs, arXiv preprint arXiv:1412.7062.
- [98] F. Yu, V. Koltun, Multi-scale context aggregation by dilated convolutions, arXiv preprint arXiv:1511.07122.
- [99] L.-C. Chen, G. Papandreou, I. Kokkinos, K. Murphy, A. L. Yuille, Deeplab: Semantic image segmentation with deep convolutional nets, atrous convolution, and fully connected crfs, IEEE transactions on pattern analysis and machine intelligence 40 (4) (2018) 834–848.
- [100] L.-C. Chen, G. Papandreou, F. Schroff, H. Adam, Rethinking atrous convolution for semantic image segmentation, arXiv preprint arXiv:1706.05587.
- [101] L.-C. Chen, Y. Zhu, G. Papandreou, F. Schroff, H. Adam, Encoder-decoder with atrous separable convolution for semantic image segmentation, arXiv preprint arXiv:1802.02611.
- [102] M. Trembl, J. Arjona-Medina, T. Unterthiner, R. Durgesh, F. Friedmann, P. Schuberth, A. Mayr, M. Heusel, M. Hofmarcher, M. Widrich, et al., Speeding up semantic segmentation for autonomous driving, in: MLITS, NIPS Workshop, 2016.
- [103] P. Wang, P. Chen, Y. Yuan, D. Liu, Z. Huang, X. Hou, G. Cottrell, Understanding convolution for semantic segmentation, arXiv preprint arXiv:1702.08502.
- [104] F. Yu, V. Koltun, T. A. Funkhouser, Dilated residual networks., in: CVPR, Vol. 2, 2017, p. 3.
- [105] Z. Wu, C. Shen, A. v. d. Hengel, High-performance semantic segmentation using very deep fully convolutional networks, arXiv preprint arXiv:1604.04339.
- [106] M. Holschneider, R. Kronland-Martinet, J. Morlet, P. Tchamitchian, A real-time algorithm for signal analysis with the help of the wavelet transform, in: Wavelets, Springer, 1990, pp. 286–297.
- [107] J. M. Alvarez, Y. LeCun, T. Gevers, A. M. Lopez, Semantic road segmentation via multi-scale ensembles of learned features, in: European Conference on Computer Vision, Springer, 2012, pp. 586–595.
- [108] C. Farabet, C. Couprie, L. Najman, Y. LeCun, Learning hierarchical features for scene labeling, IEEE transactions on pattern analysis and machine intelligence 35 (8) (2013) 1915–1929.
- [109] C. Couprie, C. Farabet, L. Najman, Y. LeCun, Indoor semantic segmentation using depth information, arXiv preprint arXiv:1301.3572.
- [110] S. Liu, X. Qi, J. Shi, H. Zhang, J. Jia, Multi-scale patch aggregation (mpa) for simultaneous detection and segmentation, in: Proceedings of the IEEE Conference on Computer Vision and Pattern Recognition, 2016, pp. 3141–3149.
- [111] B. Hariharan, P. Arbeláez, R. Girshick, J. Malik, Hypercolumns for object segmentation and fine-grained localization, in: Proceedings of the IEEE conference on computer vision and pattern recognition, 2015, pp. 447–456.
- [112] H. Zhao, J. Shi, X. Qi, X. Wang, J. Jia, Pyramid scene parsing network, in: IEEE Conf. on Computer Vision and Pattern Recognition (CVPR), 2017, pp. 2881–2890.
- [113] D. M. Vo, S.-W. Lee, Semantic image segmentation using fully convolutional neural networks with multi-scale images and multi-scale dilated convolutions, Multimedia Tools and Applications (2018) 1–19.
- [114] I. J. Goodfellow, D. Warde-Farley, M. Mirza, A. Courville, Y. Bengio, Maxout networks, arXiv preprint arXiv:1302.4389.
- [115] H. Ding, X. Jiang, B. Shuai, A. Q. Liu, G. Wang, Context contrasted feature and gated multi-scale aggregation for scene segmentation, in: Proceedings of the IEEE Conference on Computer Vision and Pattern Recognition, 2018, pp. 2393–2402.
- [116] D. Lin, G. Chen, D. Cohen-Or, P.-A. Heng, H. Huang, Cascaded feature network for semantic segmentation of rgb-d images, in: Computer Vision (ICCV), 2017 IEEE International Conference on, IEEE, 2017, pp. 1320–1328.
- [117] M. Mostajabi, P. Yadollahpour, G. Shakhnarovich, Feedforward semantic segmentation with zoom-out features, in: Proceedings of the IEEE conference on computer vision and pattern recognition, 2015, pp. 3376–3385.
- [118] R. Achanta, A. Shaji, K. Smith, A. Lucchi, P. Fua, S. Süsstrunk, et al., Slic superpixels compared to state-of-the-art superpixel methods, IEEE transactions on pattern analysis and machine intelligence 34 (11) (2012) 2274–2282.
- [119] D. Pathak, E. Shelhamer, J. Long, T. Darrell, Fully convolutional multi-class multiple instance learning, arXiv preprint arXiv:1412.7144.
- [120] P. O. Pinheiro, R. Collobert, From image-level to pixel-level labeling with convolutional networks, in: Proceedings of the IEEE Conference on Computer Vision and Pattern Recognition, 2015, pp. 1713–1721.
- [121] S. Boyd, L. Vandenberghe, Convex optimization, Cambridge university press, 2004.
- [122] S. Hong, H. Noh, B. Han, Decoupled deep neural network for semi-supervised semantic segmentation, in: Advances in neural information processing systems, 2015, pp. 1495–1503.
- [123] G. Papandreou, L.-C. Chen, K. P. Murphy, A. L. Yuille, Weakly-and semi-supervised learning of a deep convolutional network for semantic image segmentation, in: Proceedings of the IEEE international conference on computer vision, 2015, pp. 1742–1750.
- [124] Z. Huang, X. Wang, J. Wang, W. Liu, J. Wang, Weakly-supervised semantic segmentation network with deep seeded region growing, in: Proceedings of the IEEE Conference on Computer Vision and Pattern Recognition, 2018, pp. 7014–7023.
- [125] P. Luo, G. Wang, L. Lin, X. Wang, Deep dual learning for semantic image segmentation, in: Proceedings of the IEEE Conference on Computer Vision and Pattern Recognition, Honolulu, HI, USA, 2017, pp. 21–26.
- [126] N. Souly, C. Spampinato, M. Shah, Semi and weakly supervised semantic segmentation using generative adversarial network, arXiv preprint arXiv:1703.09695.
- [127] W.-C. Hung, Y.-H. Tsai, Y.-T. Liou, Y.-Y. Lin, M.-H. Yang, Adversarial learning for semi-supervised semantic segmentation, arXiv preprint arXiv:1802.07934.
- [128] D. Barnes, W. Maddern, I. Posner, Find your own way: Weakly-supervised segmentation of path proposals for urban autonomy, in: Robotics and Automation (ICRA), 2017 IEEE International Conference on, IEEE, 2017, pp. 203–210.
- [129] F. Saleh, M. S. Aliakbarian, M. Salzmann, L. Petersson, S. Gould, J. M. Alvarez, Built-in foreground/background prior for weakly-supervised semantic segmentation, in: European Conference on Computer Vision, Springer, 2016, pp. 413–432.
- [130] F. S. Saleh, M. S. Aliakbarian, M. Salzmann, L. Petersson, J. M. Alvarez, S. Gould, Incorporating network built-in priors in weakly-supervised semantic segmentation, IEEE transactions on pattern analysis and machine intelligence 40 (6) (2018) 1382–1396.
- [131] S. Saito, T. Kerola, S. Tsutsui, Superpixel clustering with deep features for unsupervised road segmentation, arXiv preprint arXiv:1711.05998.
- [132] Z. Huang, X. Wang, J. Wang, W. Liu, J. Wang, Weakly-supervised semantic segmentation network with deep seeded region growing, in: Proceedings of the IEEE Conference on Computer Vision and Pattern Recognition, 2018, pp. 7014–7023.
- [133] Y. Wei, H. Xiao, H. Shi, Z. Jie, J. Feng, T. S. Huang, Revisiting dilated convolution: A simple approach for weakly-and semi-supervised semantic segmentation, in: Proceedings of the IEEE Conference on Computer Vision and Pattern Recognition, 2018, pp. 7268–7277.
- [134] L. Ye, Z. Liu, Y. Wang, Learning semantic segmentation with diverse supervision, arXiv preprint arXiv:1802.00509.
- [135] J. Dai, K. He, J. Sun, Boxesup: Exploiting bounding boxes to supervise convolutional networks for semantic segmentation, in: Proceedings of the IEEE International Conference on Computer Vision, 2015, pp. 1635–1643.
- [136] Z. Wu, C. Shen, A. v. d. Hengel, Bridging category-level and instance-level semantic image segmentation, arXiv preprint arXiv:1605.06885.
- [137] A. Khoreva, R. Benenson, J. H. Hosang, M. Hein, B. Schiele, Simple does it: Weakly supervised instance and semantic segmentation., in: CVPR, Vol. 1, 2017, p. 3.
- [138] O. Maron, T. Lozano-Pérez, A framework for multiple-instance learning, in: Advances in neural information processing systems, 1998, pp. 570–576.
- [139] A. Khoreva, R. Benenson, J. H. Hosang, M. Hein, B. Schiele, Simple does it: Weakly supervised instance and semantic segmentation., in: CVPR, Vol. 1, 2017, p. 3.
- [140] C. Rother, V. Kolmogorov, A. Blake, Grabcut: Interactive foreground extraction using iterated graph cuts, in: ACM transactions on graphics (TOG), Vol. 23, ACM, 2004, pp. 309–314.
- [141] B. Zhou, A. Khosla, A. Lapedriza, A. Oliva, A. Torralba, Learning deep features for discriminative localization, in: Proceedings of the IEEE Conference on Computer Vision and Pattern Recognition, 2016, pp.

- 2921–2929.
- [142] I. Goodfellow, J. Pouget-Abadie, M. Mirza, B. Xu, D. Warde-Farley, S. Ozair, A. Courville, Y. Bengio, Generative adversarial nets, in: *Advances in neural information processing systems*, 2014, pp. 2672–2680.
- [143] Y. Wei, X. Liang, Y. Chen, X. Shen, M.-M. Cheng, J. Feng, Y. Zhao, S. Yan, Stc: A simple to complex framework for weakly-supervised semantic segmentation, *IEEE transactions on pattern analysis and machine intelligence* 39 (11) (2017) 2314–2320.
- [144] E. Shelhamer, K. Rakelly, J. Hoffman, T. Darrell, Clockwork convnets for video semantic segmentation, in: *European Conference on Computer Vision*, Springer, 2016, pp. 852–868.
- [145] M. Fayyaz, M. H. Saffar, M. Sabokrou, M. Fathy, R. Klette, F. Huang, Sfcfn: spatio-temporal fcn for semantic video segmentation, *arXiv preprint arXiv:1608.05971*.
- [146] Y. He, W.-C. Chiu, M. Keuper, M. Fritz, S. Campus, Std2p: Rgb-d semantic segmentation using spatio-temporal data-driven pooling., in: *CVPR*, 2017, pp. 7158–7167.
- [147] A. Kundu, V. Vineet, V. Koltun, Feature space optimization for semantic video segmentation, in: *Proceedings of the IEEE Conference on Computer Vision and Pattern Recognition*, 2016, pp. 3168–3175.
- [148] Z. Qiu, T. Yao, T. Mei, Learning deep spatio-temporal dependence for semantic video segmentation, *IEEE Transactions on Multimedia* 20 (4) (2018) 939–949.
- [149] M. Siam, S. Valipour, M. Jagersand, N. Ray, Convolutional gated recurrent networks for video segmentation, in: *Image Processing (ICIP)*, 2017 IEEE International Conference on, IEEE, 2017, pp. 3090–3094.
- [150] F. Saleh, M. S. A. Akbarian, M. Salzmann, L. Petersson, J. M. Alvarez, Bringing background into the foreground: Making all classes equal in weakly-supervised video semantic segmentation., in: *ICCV*, 2017, pp. 2125–2135.
- [151] D. Nilsson, C. Sminchisescu, Semantic video segmentation by gated recurrent flow propagation, *arXiv preprint arXiv:1612.08871* 2.
- [152] D. Tran, L. Bourdev, R. Fergus, L. Torresani, M. Paluri, Learning spatiotemporal features with 3d convolutional networks, in: *Proceedings of the IEEE International Conference on Computer Vision*, 2015, pp. 4489–4497.
- [153] M. S. Pavel, H. Schulz, S. Behnke, Object class segmentation of rgb-d video using recurrent convolutional neural networks, *Neural Networks* 88 (2017) 105–113.
- [154] E. E. Yurdakul, Y. Yemez, Semantic segmentation of rgb-d videos with recurrent fully convolutional neural networks., in: *ICCV Workshops*, 2017, pp. 367–374.
- [155] N. Ballas, L. Yao, C. Pal, A. Courville, Delving deeper into convolutional networks for learning video representations, *arXiv preprint arXiv:1511.06432*.
- [156] J. Koutnik, K. Greff, F. Gomez, J. Schmidhuber, A clockwork rnn, *arXiv preprint arXiv:1402.3511*.
- [157] S. Chandra, C. Camille, I. Kokkinos, Deep spatio-temporal random fields for efficient video segmentation, in: *Proceedings of the IEEE Conference on Computer Vision and Pattern Recognition*, 2018, pp. 8915–8924.
- [158] S. Chandra, I. Kokkinos, Fast, exact and multi-scale inference for semantic image segmentation with deep gaussian crfs, in: *European Conference on Computer Vision*, Springer, 2016, pp. 402–418.
- [159] A. Arnab, S. Zheng, S. Jayasumana, B. Romera-Paredes, M. Larsson, A. Kirillov, B. Savchynskyy, C. Rother, F. Kahl, P. Torr, Conditional random fields meet deep neural networks for semantic segmentation, *IEEE Signal Processing Magazine* 2.
- [160] P. Krähenbühl, V. Koltun, Efficient inference in fully connected crfs with gaussian edge potentials, in: *Advances in neural information processing systems*, 2011, pp. 109–117.
- [161] A. Adams, J. Baek, M. A. Davis, Fast high-dimensional filtering using the permutohedral lattice, in: *Computer Graphics Forum*, Vol. 29, Wiley Online Library, 2010, pp. 753–762.
- [162] S. Zheng, S. Jayasumana, B. Romera-Paredes, V. Vineet, Z. Su, D. Du, C. Huang, P. H. Torr, Conditional random fields as recurrent neural networks, in: *Proceedings of the IEEE international conference on computer vision*, 2015, pp. 1529–1537.
- [163] R. Vemulapalli, O. Tuzel, M.-Y. Liu, R. Chellapa, Gaussian conditional random field network for semantic segmentation, in: *Proceedings of the IEEE Conference on Computer Vision and Pattern Recognition*, 2016, pp. 3224–3233.
- [164] M. T. Teichmann, R. Cipolla, Convolutional crfs for semantic segmentation, *arXiv preprint arXiv:1805.04777*.
- [165] A. Arnab, S. Jayasumana, S. Zheng, P. H. Torr, Higher order conditional random fields in deep neural networks, in: *European Conference on Computer Vision*, Springer, 2016, pp. 524–540.
- [166] F. Shen, R. Gan, S. Yan, G. Zeng, Semantic segmentation via structured patch prediction, context crf and guidance crf, in: *IEEE Conference on Computer Vision and Pattern Recognition*, Vol. 8, 2017.
- [167] Z. Liu, X. Li, P. Luo, C.-C. Loy, X. Tang, Semantic image segmentation via deep parsing network, in: *Proceedings of the IEEE International Conference on Computer Vision*, 2015, pp. 1377–1385.
- [168] G. Lin, C. Shen, I. Reid, A. van den Hengel, Deeply learning the messages in message passing inference, in: C. Cortes, N. D. Lawrence, D. D. Lee, M. Sugiyama, R. Garnett (Eds.), *Advances in Neural Information Processing Systems* 28, Curran Associates, Inc., 2015, pp. 361–369.
- [169] G. Lin, C. Shen, A. Van Den Hengel, I. Reid, Efficient piecewise training of deep structured models for semantic segmentation, in: *Proceedings of the IEEE Conference on Computer Vision and Pattern Recognition*, 2016, pp. 3194–3203.
- [170] J. Jiang, Z. Zhang, Y. Huang, L. Zheng, Incorporating depth into both cnn and crf for indoor semantic segmentation, in: *Software Engineering and Service Science (ICSESS)*, 2017 8th IEEE International Conference on, IEEE, 2017, pp. 525–530.
- [171] V. Jampani, M. Kiefel, P. V. Gehler, Learning sparse high dimensional filters: Image filtering, dense crfs and bilateral neural networks, in: *Proceedings of the IEEE Conference on Computer Vision and Pattern Recognition*, 2016, pp. 4452–4461.
- [172] J. T. Barron, B. Poole, The fast bilateral solver, in: *European Conference on Computer Vision*, Springer, 2016, pp. 617–632.
- [173] G. Bertasius, J. Shi, L. Torresani, Semantic segmentation with boundary neural fields, in: *Proceedings of the IEEE Conference on Computer Vision and Pattern Recognition*, 2016, pp. 3602–3610.
- [174] L.-C. Chen, J. T. Barron, G. Papandreou, K. Murphy, A. L. Yuille, Semantic image segmentation with task-specific edge detection using cnns and a discriminatively trained domain transform, in: *Proceedings of the IEEE Conference on Computer Vision and Pattern Recognition*, 2016, pp. 4545–4554.
- [175] C. Peng, X. Zhang, G. Yu, G. Luo, J. Sun, Large kernel matters improve semantic segmentation by global convolutional network, in: *Computer Vision and Pattern Recognition (CVPR)*, 2017 IEEE Conference on, IEEE, 2017, pp. 1743–1751.
- [176] G. Bertasius, L. Torresani, X. Y. Stella, J. Shi, Convolutional random walk networks for semantic image segmentation., in: *CVPR*, 2017, pp. 6137–6145.
- [177] L. Lovász, et al., Random walks on graphs: A survey, *Combinatorics, Paul erdos is eighty 2* (1) (1993) 1–46.
- [178] A. Adams, J. Baek, M. A. Davis, Fast high-dimensional filtering using the permutohedral lattice, in: *Computer Graphics Forum*, Vol. 29, Wiley Online Library, 2010, pp. 753–762.
- [179] E. S. Gastal, M. M. Oliveira, Domain transform for edge-aware image and video processing, in: *ACM Transactions on Graphics (ToG)*, Vol. 30, ACM, 2011, p. 69.
- [180] G. J. Brostow, J. Fauqueur, R. Cipolla, Semantic object classes in video: A high-definition ground truth database, *Pattern Recognition Letters* 30 (2) (2009) 88–97.
- [181] T. Scharwächter, M. Enzweiler, U. Franke, S. Roth, Efficient multi-cue scene segmentation, in: *German Conference on Pattern Recognition*, Springer, 2013, pp. 435–445.
- [182] M. Cordts, M. Omran, S. Ramos, T. Scharwächter, M. Enzweiler, R. Benenson, U. Franke, S. Roth, B. Schiele, The cityscapes dataset, in: *CVPR Workshop on the Future of Datasets in Vision*, Vol. 1, 2015, p. 3.
- [183] G. Neuhold, T. Ollmann, S. R. Bulò, P. Kotschieder, The mapillary vistas dataset for semantic understanding of street scenes., in: *ICCV*, 2017, pp. 5000–5009.
- [184] X. Huang, X. Cheng, Q. Geng, B. Cao, D. Zhou, P. Wang, Y. Lin, R. Yang, The apolloscape dataset for autonomous driving, *arXiv preprint arXiv:1803.06184*.
- [185] A. Geiger, P. Lenz, R. Urtasun, Are we ready for autonomous driving? the kitti vision benchmark suite, in: *Computer Vision and Pattern Recognition (CVPR)*, 2012 IEEE Conference on, IEEE, 2012, pp. 3354–3361.

- [186] G. Ros, L. Sellart, J. Materzynska, D. Vazquez, A. M. Lopez, The synthia dataset: A large collection of synthetic images for semantic segmentation of urban scenes, in: Proceedings of the IEEE conference on computer vision and pattern recognition, 2016, pp. 3234–3243.
- [187] S. R. Richter, V. Vineet, S. Roth, V. Koltun, Playing for data: Ground truth from computer games, in: European Conference on Computer Vision, Springer, 2016, pp. 102–118.
- [188] M. Everingham, S. A. Eslami, L. Van Gool, C. K. Williams, J. Winn, A. Zisserman, The pascal visual object classes challenge: A retrospective, *International journal of computer vision* 111 (1) (2015) 98–136.
- [189] A. Krizhevsky, G. Hinton, Learning multiple layers of features from tiny images, Tech. rep., Citeseer (2009).
- [190] J. Deng, W. Dong, R. Socher, L.-J. Li, K. Li, L. Fei-Fei, Imagenet: A large-scale hierarchical image database, in: Computer Vision and Pattern Recognition, 2009. CVPR 2009. IEEE Conference on, Ieee, 2009, pp. 248–255.
- [191] F. Li, T. Kim, A. Humayun, D. Tsai, J. M. Rehg, Video segmentation by tracking many figure-ground segments, in: Proceedings of the IEEE International Conference on Computer Vision, 2013, pp. 2192–2199.
- [192] R. Mottaghi, X. Chen, X. Liu, N.-G. Cho, S.-W. Lee, S. Fidler, R. Urtasun, A. Yuille, The role of context for object detection and semantic segmentation in the wild, in: Proceedings of the IEEE Conference on Computer Vision and Pattern Recognition, 2014, pp. 891–898.
- [193] T.-Y. Lin, M. Maire, S. Belongie, J. Hays, P. Perona, D. Ramanan, P. Dollár, C. L. Zitnick, Microsoft coco: Common objects in context, in: European conference on computer vision, Springer, 2014, pp. 740–755.
- [194] B. Zhou, H. Zhao, X. Puig, S. Fidler, A. Barriuso, A. Torralba, Semantic understanding of scenes through the ade20k dataset, arXiv preprint arXiv:1608.05442.
- [195] J. Pont-Tuset, F. Perazzi, S. Caelles, P. Arbeláez, A. Sorkine-Hornung, L. Van Gool, The 2017 davis challenge on video object segmentation, arXiv preprint arXiv:1704.00675.
- [196] H. Caesar, J. Uijlings, V. Ferrari, Coco-stuff: Thing and stuff classes in context, *CoRR*, abs/1612.03716 5 (2016) 8.
- [197] N. Silberman, D. Hoiem, P. Kohli, R. Fergus, Indoor segmentation and support inference from rgb-d images, in: European Conference on Computer Vision, Springer, 2012, pp. 746–760.
- [198] H. S. Koppula, A. Anand, T. Joachims, A. Saxena, Semantic labeling of 3d point clouds for indoor scenes, in: Advances in neural information processing systems, 2011, pp. 244–252.
- [199] A. Dai, A. X. Chang, M. Savva, M. Halber, T. A. Funkhouser, M. Nießner, Scannet: Richly-annotated 3d reconstructions of indoor scenes., in: CVPR, Vol. 2, 2017, p. 10.
- [200] I. Armeni, S. Sax, A. R. Zamir, S. Savarese, Joint 2d-3d-semantic data for indoor scene understanding, arXiv preprint arXiv:1702.01105.
- [201] J. Xiao, A. Owens, A. Torralba, Sun3d: A database of big spaces reconstructed using sfm and object labels, in: Proceedings of the IEEE International Conference on Computer Vision, 2013, pp. 1625–1632.
- [202] S. Song, S. P. Lichtenberg, J. Xiao, Sun rgb-d: A rgb-d scene understanding benchmark suite, in: Proceedings of the IEEE conference on computer vision and pattern recognition, 2015, pp. 567–576.
- [203] K. Lai, L. Bo, X. Ren, D. Fox, A large-scale hierarchical multi-view rgb-d object dataset, in: Robotics and Automation (ICRA), 2011 IEEE International Conference on, IEEE, 2011, pp. 1817–1824.
- [204] S. D. Jain, K. Grauman, Supervoxel-consistent foreground propagation in video, in: European Conference on Computer Vision, Springer, 2014, pp. 656–671.
- [205] J. Shotton, J. Winn, C. Rother, A. Criminisi, Textonboost: Joint appearance, shape and context modeling for multi-class object recognition and segmentation, in: European conference on computer vision, Springer, 2006, pp. 1–15.
- [206] M. Marszalek, C. Schmid, Accurate object localization with shape masks, in: Computer Vision and Pattern Recognition, 2007. CVPR'07. IEEE Conference on, IEEE, 2007, pp. 1–8.
- [207] B. C. Russell, A. Torralba, K. P. Murphy, W. T. Freeman, Labelme: a database and web-based tool for image annotation, *International journal of computer vision* 77 (1-3) (2008) 157–173.
- [208] J. Tighe, S. Lazebnik, Superparsing: scalable nonparametric image parsing with superpixels, in: European conference on computer vision, Springer, 2010, pp. 352–365.
- [209] S. Gould, R. Fulton, D. Koller, Decomposing a scene into geometric and semantically consistent regions, in: Computer Vision, 2009 IEEE 12th International Conference on, IEEE, 2009, pp. 1–8.
- [210] B. Hariharan, P. Arbeláez, L. Bourdev, S. Maji, J. Malik, Semantic contours from inverse detectors.
- [211] C. Liu, J. Yuen, A. Torralba, Nonparametric scene parsing via label transfer, *IEEE Transactions on Pattern Analysis and Machine Intelligence* 33 (12) (2011) 2368–2382.
- [212] A. Valada, G. L. Oliveira, T. Brox, W. Burgard, Deep multispectral semantic scene understanding of forested environments using multimodal fusion, in: International Symposium on Experimental Robotics, Springer, 2016, pp. 465–477.
- [213] M.-Y. Liu, S. Lin, S. Ramalingam, O. Tuzel, Layered interpretation of street view images, arXiv preprint arXiv:1506.04723.
- [214] J. Krapac, I. K. S. Šegvic, Ladder-style densenets for semantic segmentation of large natural images, in: Computer Vision Workshop (IC-CVW), 2017 IEEE International Conference on, IEEE, 2017, pp. 238–245.
- [215] W. Wang, U. Neumann, Depth-aware cnn for rgb-d segmentation, arXiv preprint arXiv:1803.06791.
- [216] Z. Li, Y. Gan, X. Liang, Y. Yu, H. Cheng, L. Lin, Lstm-cf: Unifying context modeling and fusion with lstms for rgb-d scene labeling, in: European Conference on Computer Vision, Springer, 2016, pp. 541–557.
- [217] Y. Wang, C. Xu, C. Xu, D. Tao, Beyond filters: Compact feature map for portable deep model, in: International Conference on Machine Learning, 2017, pp. 3703–3711.
- [218] Y.-D. Kim, E. Park, S. Yoo, T. Choi, L. Yang, D. Shin, Compression of deep convolutional neural networks for fast and low power mobile applications, arXiv preprint arXiv:1511.06530.
- [219] A. Holliday, M. Barekatin, J. Laurmaa, C. Kandaswamy, H. Prendinger, Speedup of deep learning ensembles for semantic segmentation using a model compression technique, *Computer Vision and Image Understanding* 164 (2017) 16–26.
- [220] J. Hoffman, D. Wang, F. Yu, T. Darrell, Fcns in the wild: Pixel-level adversarial and constraint-based adaptation, arXiv preprint arXiv:1612.02649.
- [221] Y. Zhang, P. David, B. Gong, Curriculum domain adaptation for semantic segmentation of urban scenes, in: The IEEE International Conference on Computer Vision (ICCV), Vol. 2, 2017, p. 6.
- [222] S. Sankaranarayanan, Y. Balaji, A. Jain, S. N. Lim, R. Chellappa, Learning from synthetic data: Addressing domain shift for semantic segmentation, in: The IEEE Conference on Computer Vision and Pattern Recognition (CVPR), 2018.
- [223] N. Ma, X. Zhang, H.-T. Zheng, J. Sun, Shufflenet v2: Practical guidelines for efficient cnn architecture design, arXiv preprint arXiv:1807.11164 1.
- [224] A. G. Howard, M. Zhu, B. Chen, D. Kalenichenko, W. Wang, T. Weyand, M. Andreetto, H. Adam, Mobilenets: Efficient convolutional neural networks for mobile vision applications, arXiv preprint arXiv:1704.04861.
- [225] H. Li, A. Kadav, I. Durdanovic, H. Samet, H. P. Graf, Pruning filters for efficient convnets, *CoRR* abs/1608.08710.
- [226] M. Jaderberg, A. Vedaldi, A. Zisserman, Speeding up convolutional neural networks with low rank expansions, arXiv preprint arXiv:1405.3866.
- [227] R. Zhang, G. Li, M. Li, L. Wang, Fusion of images and point clouds for the semantic segmentation of large-scale 3d scenes based on deep learning, *ISPRS Journal of Photogrammetry and Remote Sensing*.
- [228] M. Yousefhusien, D. J. Kelbe, E. J. Intellicci, C. Salvaggio, A multi-scale fully convolutional network for semantic labeling of 3d point clouds, *ISPRS Journal of Photogrammetry and Remote Sensing*.
- [229] R. Q. Charles, H. Su, M. Kaichun, L. J. Guibas, Pointnet: Deep learning on point sets for 3d classification and segmentation, in: Computer Vision and Pattern Recognition (CVPR), 2017 IEEE Conference on, IEEE, 2017, pp. 77–85.
- [230] Y. Li, J. Shi, D. Lin, Low-latency video semantic segmentation, in: Proceedings of the IEEE Conference on Computer Vision and Pattern Recognition, 2018, pp. 5997–6005.